

benvenuti al rifugio . . .

wilkommen im refugium . . .

struttura | gliederung

lageplan

piano nero		4-5
planimetria		6-7
la vita a briano		8-9
concetto		10-11
pianta		12-13
zona giorno-notte		14-19
dettagli zona giorno-notte		20-25
cucina		26-31
dettagli di cucina		32-33
bagno		34-37
lucernario riempito d`acqua		38-39
illuminazione		40-41
pianta tecnica		42-43
sezione longitudinale		44-47
sezione spaccate		48-49
prospettiva		50-51
impronta		52



piano nero | schwarzplan

m 1:5000





planimetria | lagesplan
m 1:1000



der innenraum ist da um nach außen zu schauen und von außen muss nicht alles im inneren ersichtlich sein .

l'interno c`è per guardare all'estero e dall'esterno non tutto deve essere visibile nel interno .



il luogo | briano - un luogo nella riserva naturale ad un'altitudine di 1000 metri sulle montagne del lago di garda.

der ort | briano - ein ort im naturschutzgebiet auf 1000m höhe in den bergen am gardasee .

un rifugio | in un antico casale italiano .
20 m² per stefano e i suoi ospiti .

ein refugium | ein rückzugsort in einem alten, italienischen bauernhaus . 20 m² für stefano und seine gäste .

stefano basevi | una vita di semplicità e connessione con la natura. ricordi con amici e famiglia .

stefano basevi | ein leben in einfachheit und die verbundtheit zur natur . das teilen von erinnerungen mit freunden und familie .

la vita a briano
das leben in briano

a c q u a | trasmette la riflessione e la magia
 w a s e r | sinn von reflektien und magie



l i m o n e | senso dei colori e della freschezza
 z i t r o n e | sinn der farbe und der frische



l e g n o | trasmette la presenza e la tradizione
 h o l z | sinn der präzision, tradition





das gefühl des sees ganz oben in den bergen .

il sentimento del lago lassù nelle montagne .



pianta | grundriss

m 1:33





arrivare | ankommen



rilassare | entspannen



dormire | schlafen

intonaco di calce
kalkputz

pietra naturale
naturstein

laccatura gialla
gelbe lackierung

tessuto verde
grüner stoff

legno vecchio
altholz

pavimento in pietra naturale
natursteinboden

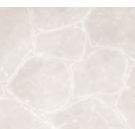
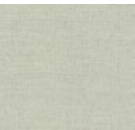



vista | ansicht a



vista | ansicht c

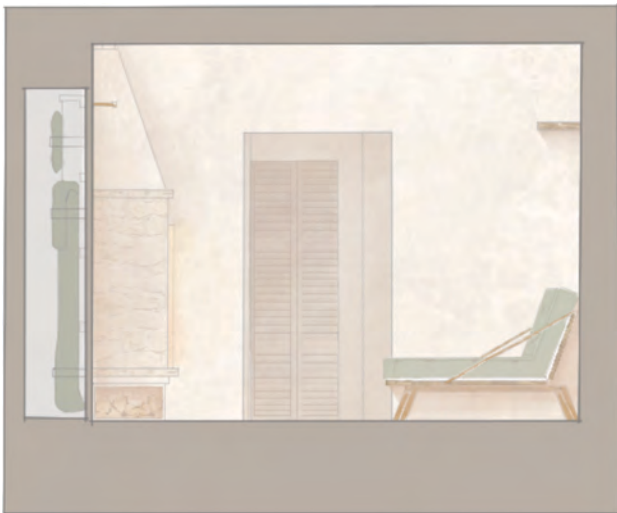

vista | ansicht b



vista | ansicht d

zona giorno notte | visualizzazione
wohn-schlafbereich | visualisierungen

m 1:50

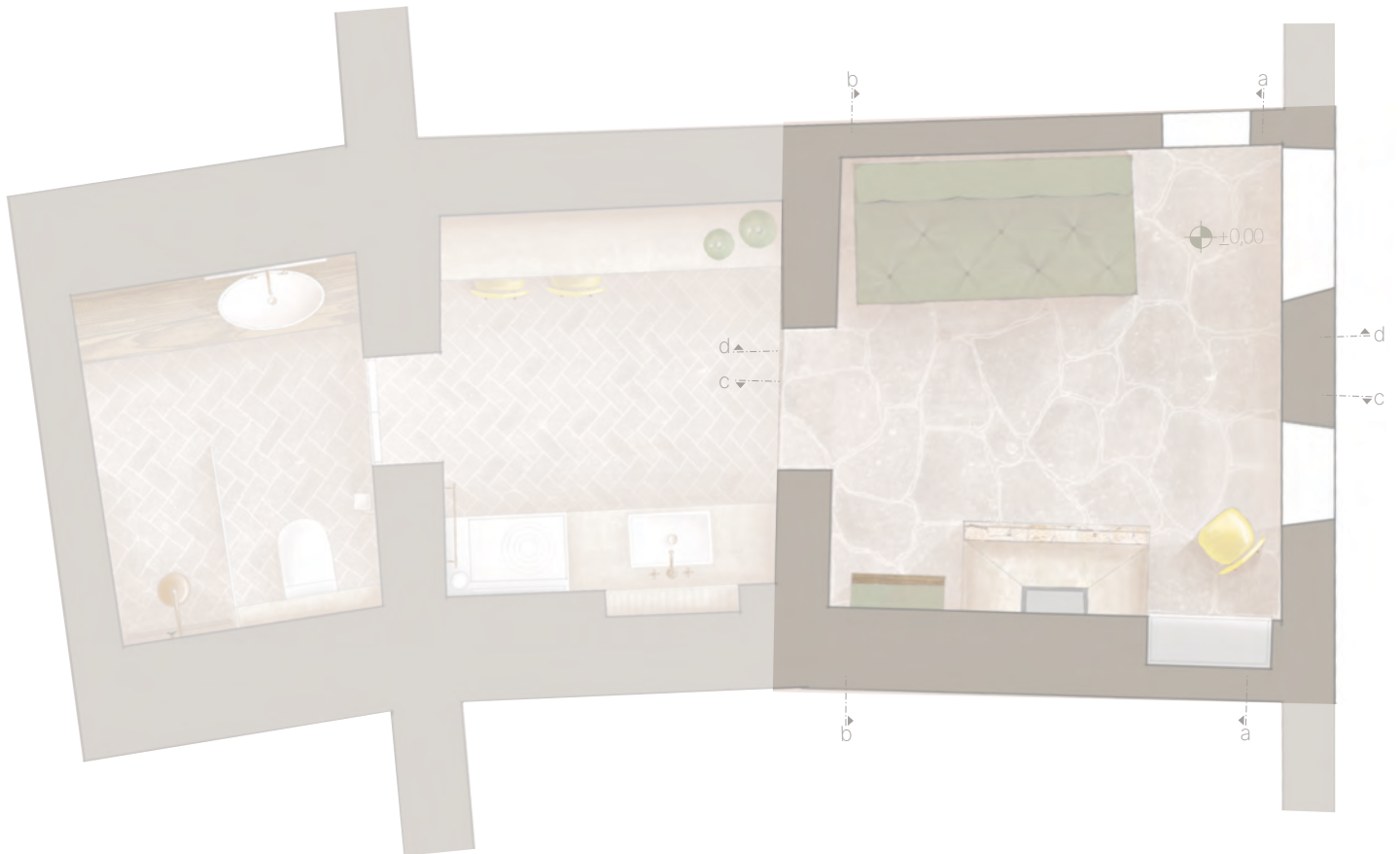



vista | ansicht a



vista | ansicht c



vista | ansicht b



vista | ansicht d

zona giorno-notte | visualizzazione
wohn-schlafbereich | visualisierungen

m 1:50

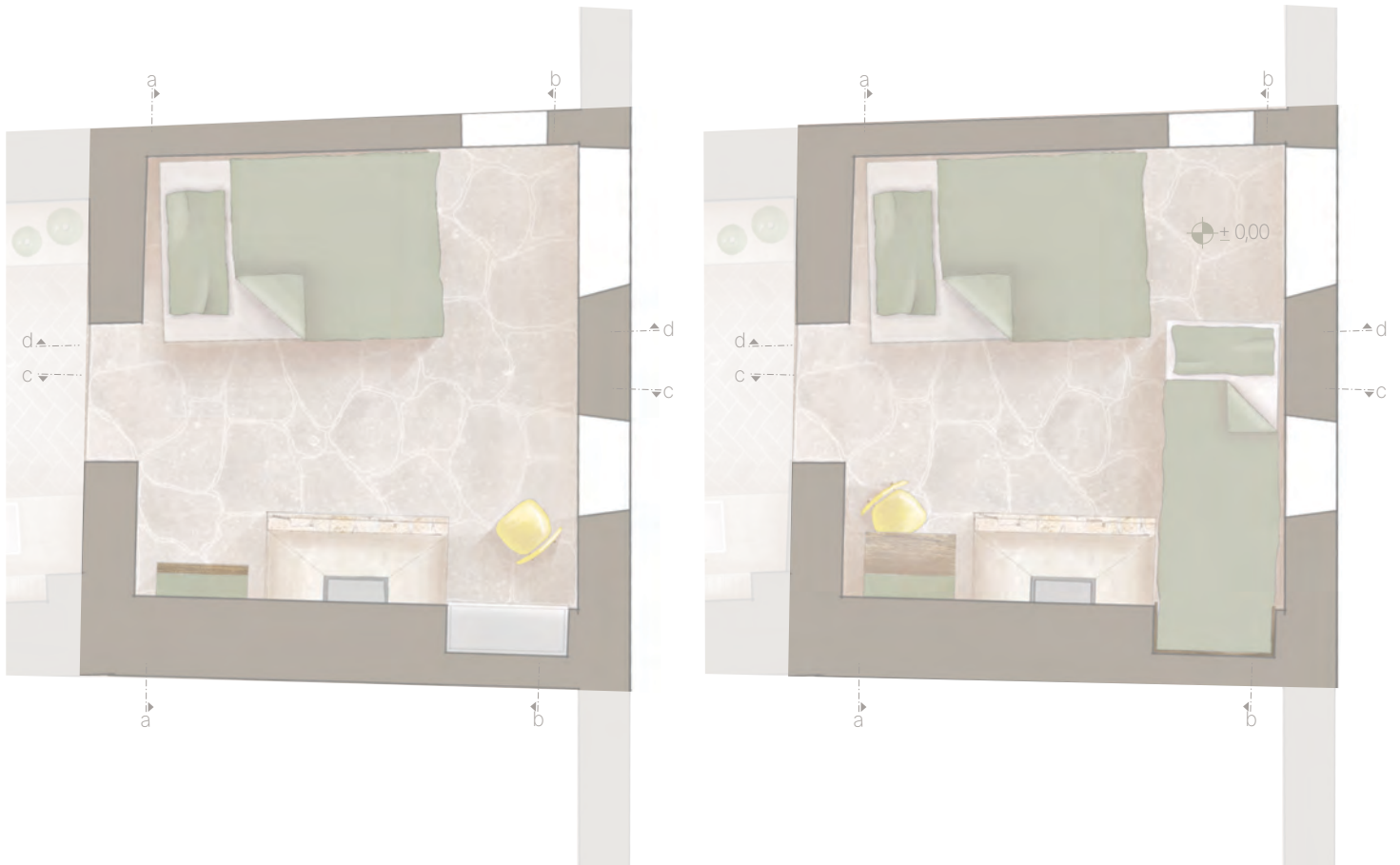

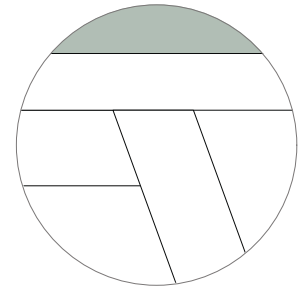
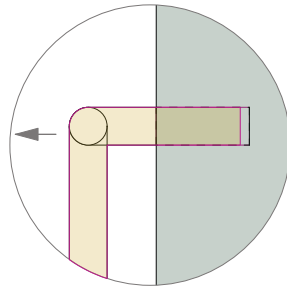
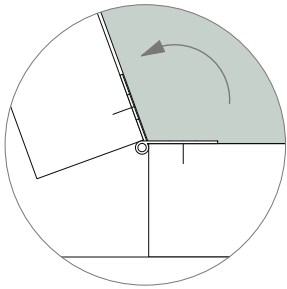
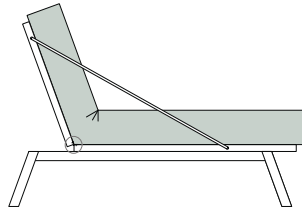

cerniera in bronzo della ditta häfele .
fissata con un semplice collegamento a vite .

scharnierband in bronzo von der firma häfele .
fixiert mit einer einfachen schraubenverbindung .

la barra in bronzo fissa lo schienale del
divano con un semplice collegamento a
innesto .

bronze stange fixiert mit einer einfachen
steckverbindung die rückenlehne des sofas .

le gambe del divano sono costruite
con una classica connessione in legno
(connessione ad angolo con borchie).

die beine des sofas sind mit einer
klassischen holzverbindung
(stolleneckverbindung) konstruiert .

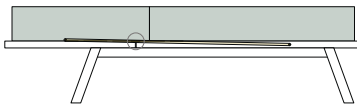
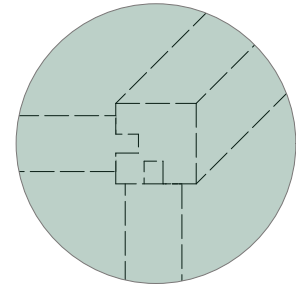
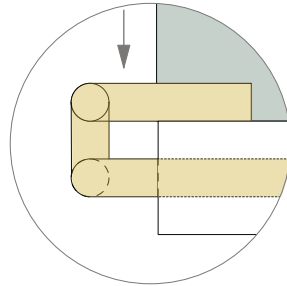
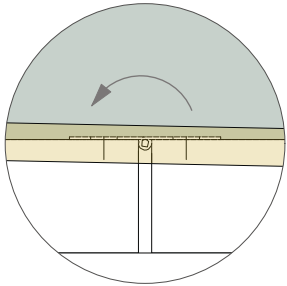

divano | dettagli
sofa | details

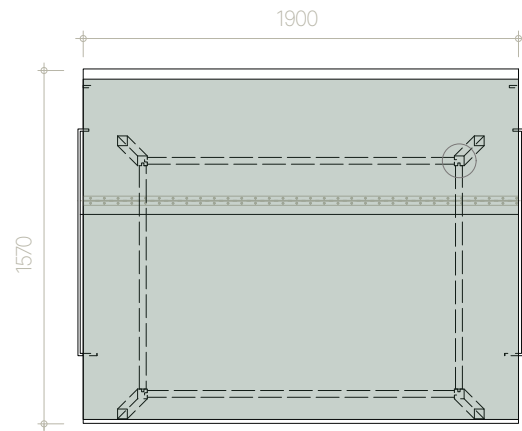
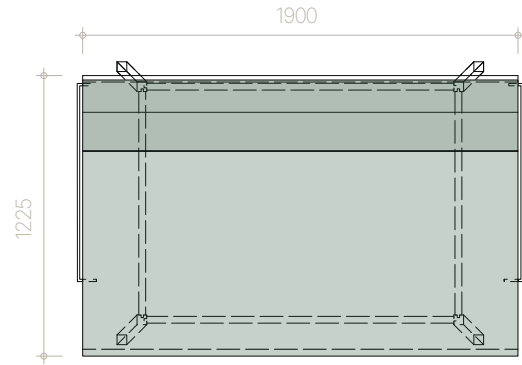
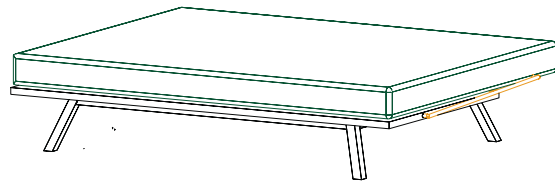
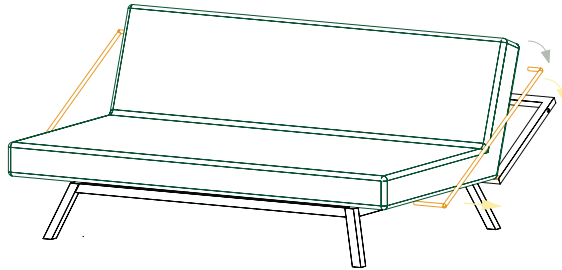
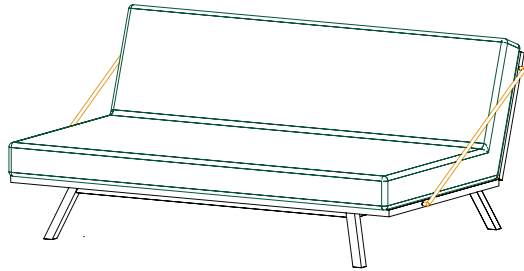

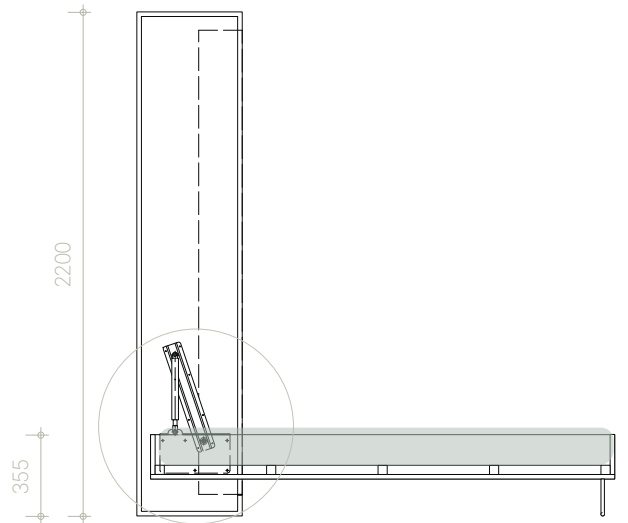
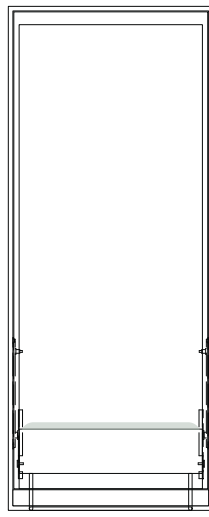
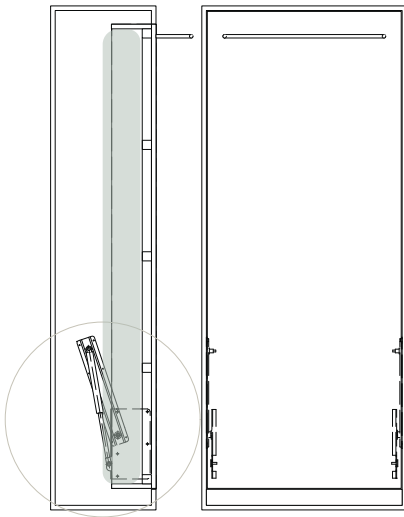
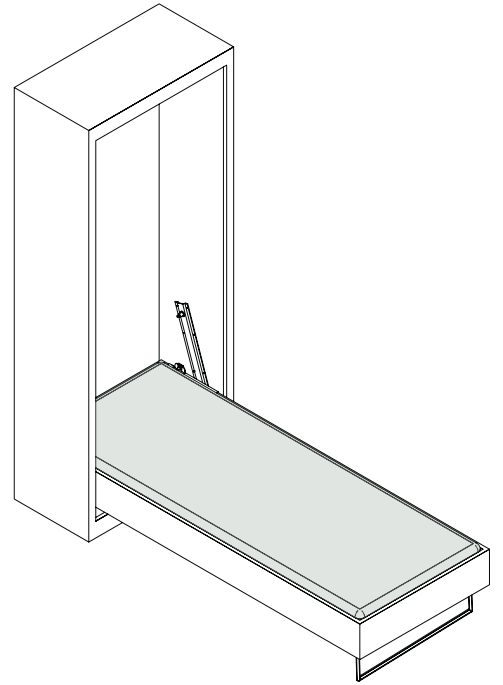
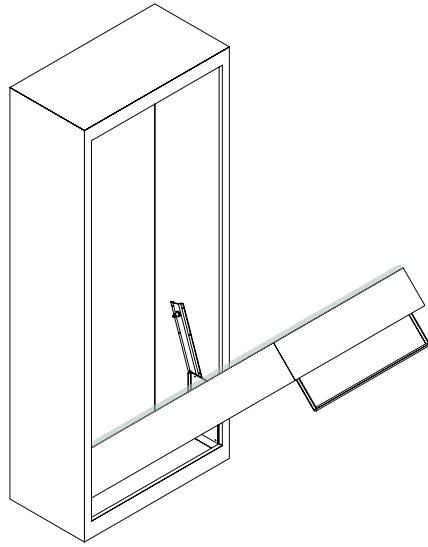
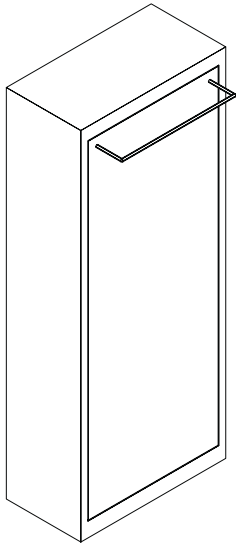

letto pieghevole | dettagli
klappbett | details

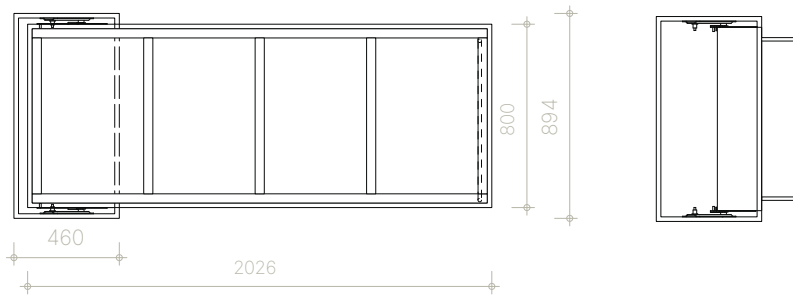

cerniera per letto pieghevole di häfele
formato letto verticale e singolo

klappbett scharnier von häfele
hochkant und einzelbettformat

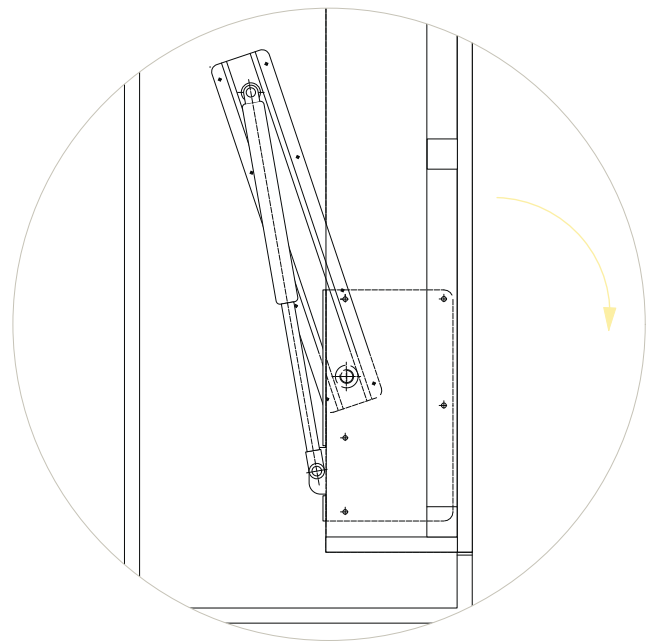
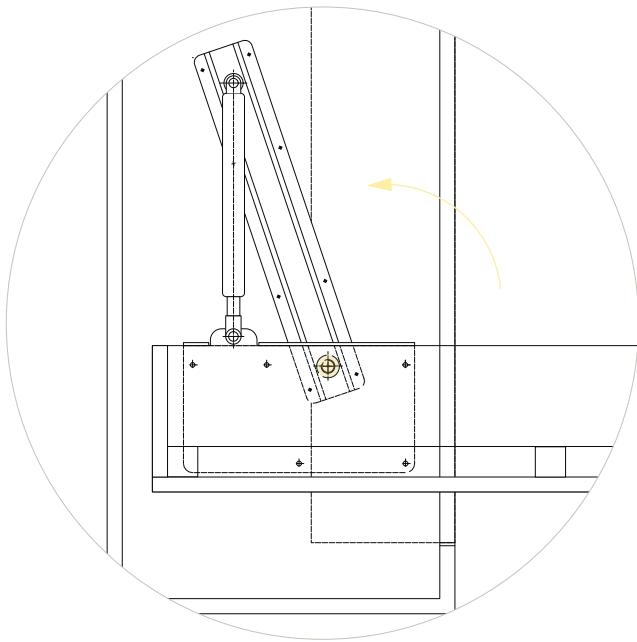

segretario e armadietto pensile | dettagli
sekretär und hängeschränken | details

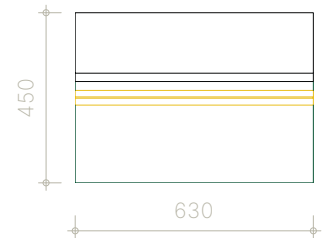
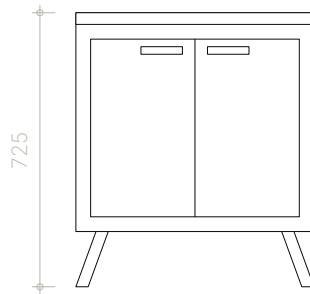
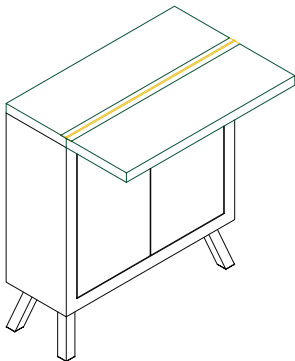
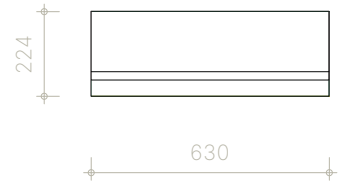
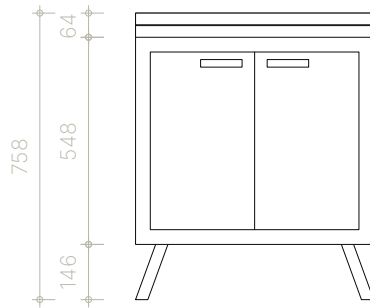
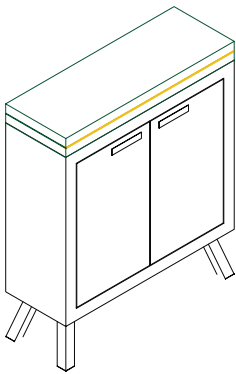
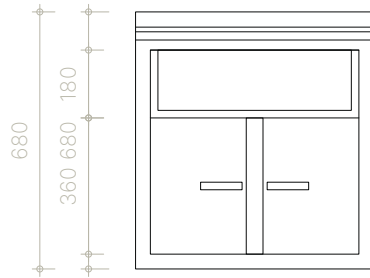
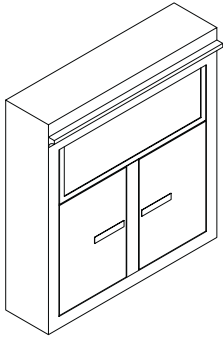

caminetto | dettagli
 feuerstelle | details



allargando la pietra calcarea e inserendo una cassetta per caminetto la quale rende il fuocolare il punto forte della zona giorno.

durch das erweitern des kalksteines und das einsetzen einer kaminkassette wird der kamin zum highlight des wohnbereiches .

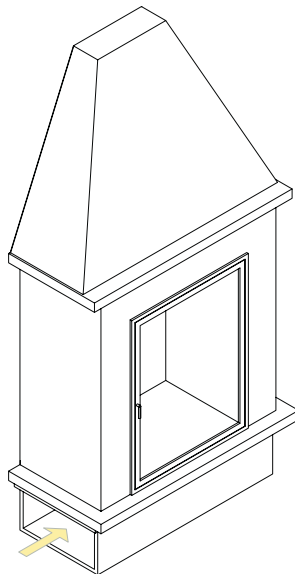
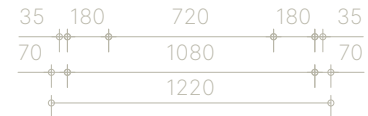
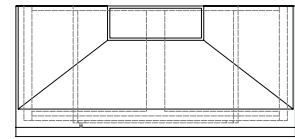

aperture laterali per il deposito della legna da ardere.

seitliche öffnungen zur lagerung des feuerholzes .

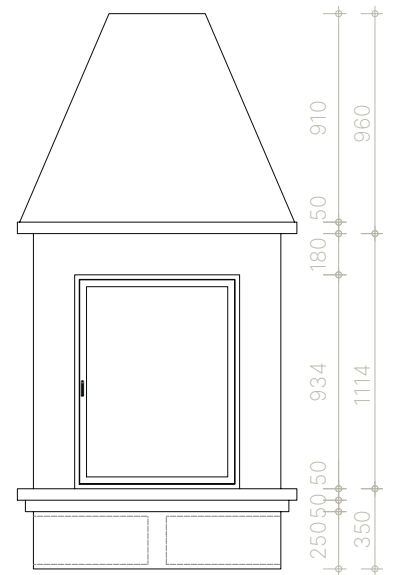
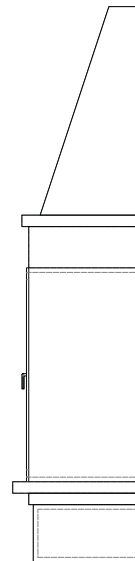

cucinare | kochen



mangiare | essen



vivere | leben





intonaco di calce
kalkputz



pietra naturale
naturstein



laccatura gialla
gelbe lackierung



ottone
messing



legno vecchio
altholz



pavimento in pietra naturale
natursteinboden





vista | ansicht a



vista | ansicht c



vista | ansicht b



vista | ansicht d

cucina | visualizzazione
küche | visualisierungen

m 1:50





vista | ansicht a



vista | ansicht c



vista | ansicht b



vista | ansicht d

cucina | visualizzazione
küche | visualisierungen

m 1:50



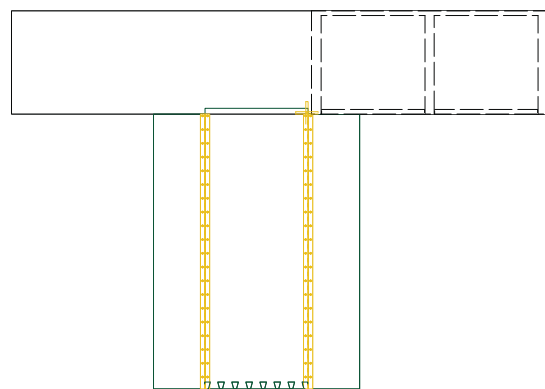
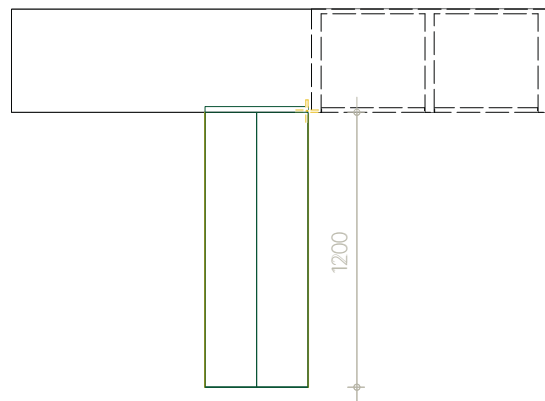
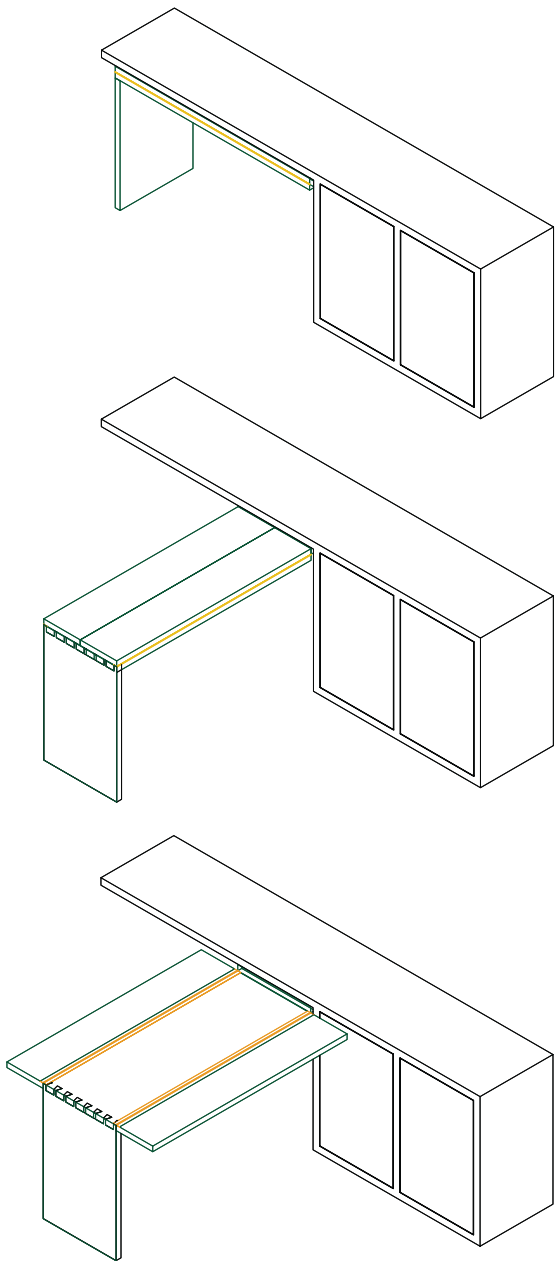

tavolo ruotabile | dettagli
drehbarer tisch | details

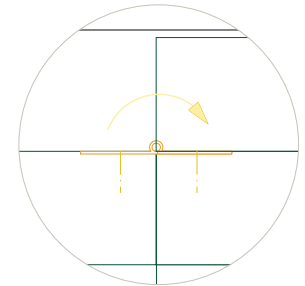
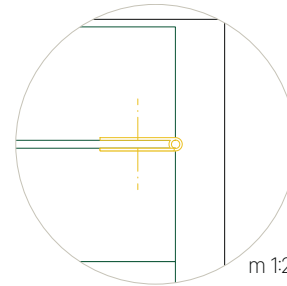
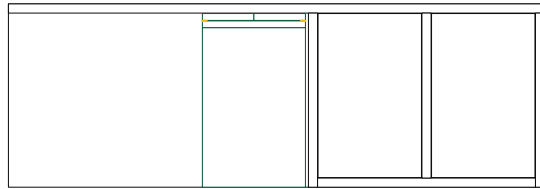
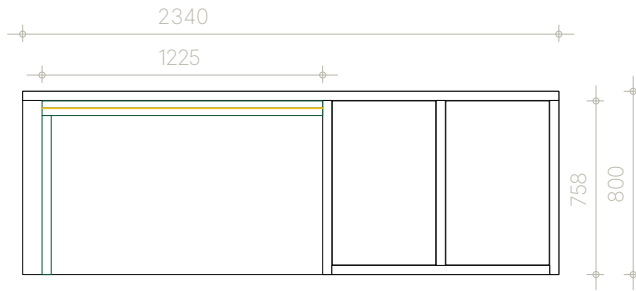

**cerniera in bronzo della ditta häfele .
fissata con un semplice collegamento a vite .**

scharnierband in bronze von der firma häfele .
fixiert mit einer einfachen schraubenverbindung .

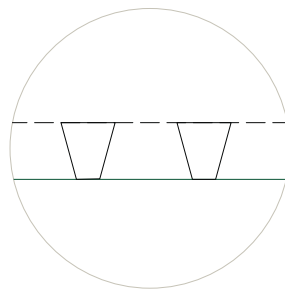
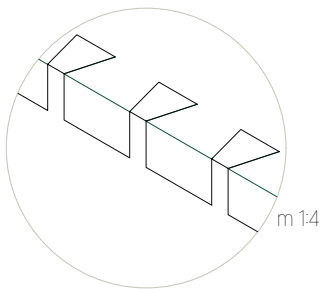

**giunzione artigianale del legno denti a coda di rondine .
handwerkliche holzverbindung schwalbenschwanz zinken .**

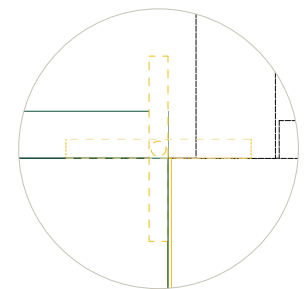
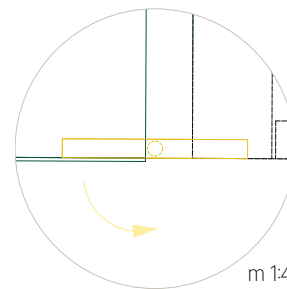

**la cerniera girevole consente un utilizzo multifunzionale
in stato aperto e chiuso .**

drehscharnier ermöglicht multifunktionale nutzung
im geöffneten und geschlossenen zustand .

rinfriscare | erfrischen

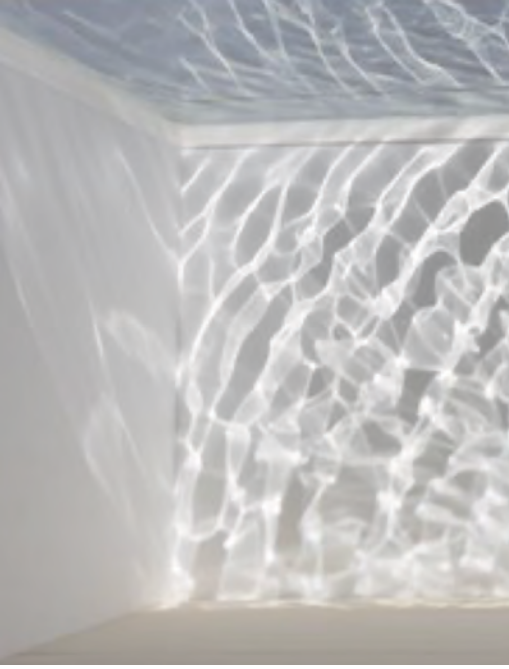

viziare | verwöhnen



incantare | verzaubern



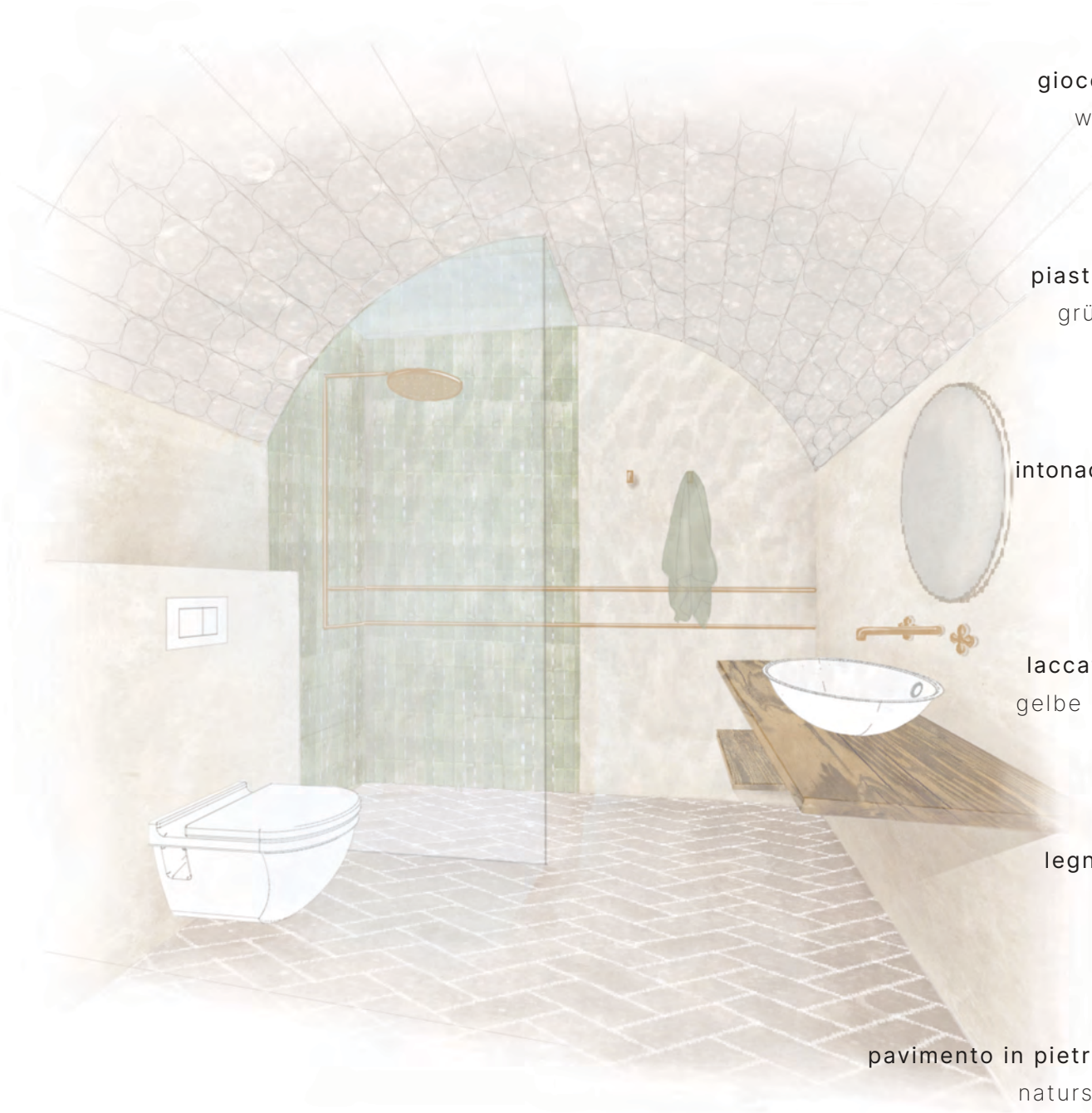

gioco d`acqua
wasserspiel



piastrelle verdi
grüne fliesen



intonaco di calce
kalkputz



laccatura gialla
gelbe lackierung



legno vecchio
altholz



pavimento in pietra naturale
natursteinboden





vista | ansicht a



vista | ansicht c



vista | ansicht b

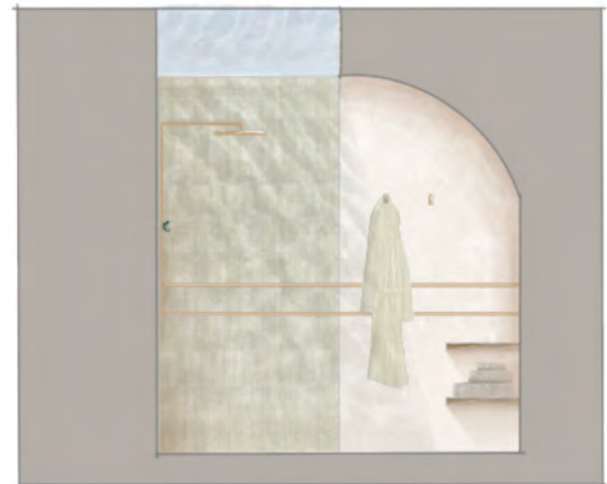

vista | ansicht d

b a g n o | visualizzazione
b a d | visualisierungen

1:50





le ore nove | la luce del mattino crea un gioco di luci sopra il lavabo

9 : 00 uhr | morgenlicht erzeugt ein lichtspiel über dem waschtisch

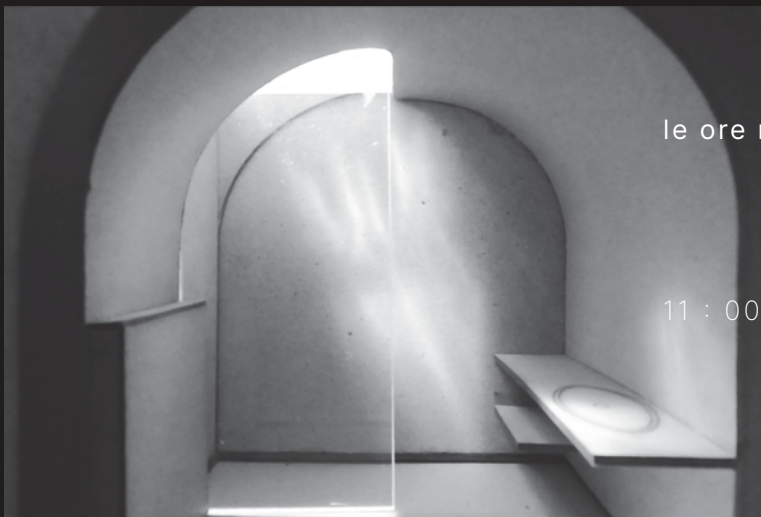

le ore nove | il sole di mezzogiorno riflette il movimento dell`acqua sulla parete

11 : 00 Uhr | mittagssonne spiegelt die wasserbewegung an der rückwand wider



le ore nove | nel pomeriggio la doccia diventa il momento clou della camera

16 : 00 Uhr | am nachmittag wird die dusche zum highlight des raumes

lucernario riempito d'acqua
wassergefülltes oberlicht



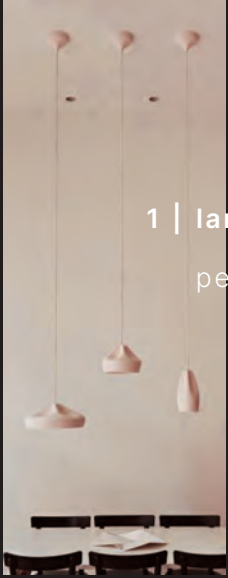

1 | lampada sospesa

pendelleuchten

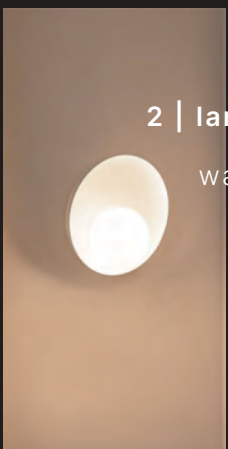
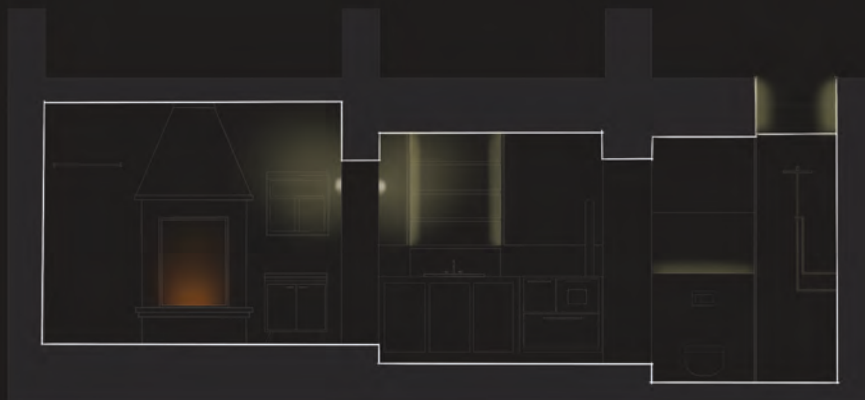

2 | lampada a parete

wandleuchten

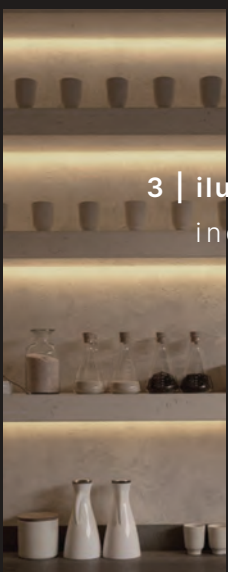

3 | illuminazione indiretta

indirekte beleuchtung

illuminazione

beleuchtung



l'illuminazione indiretta funge da luce d'atmosfera negli interni.

creando un'atmosfera calma e rilassata.

gli apparecchi a parete completano le aree necessarie con una luminosità aggiuntiva.

illuminazione accentuata nel bagno e nella sala da pranzo con apparecchi a sospensione coordinati.

indirekte beleuchtung als stimmungslicht im innen-raum .

erzeugung einer ruhigen und entspannten atmosphäre .

wandleuchten ergänzen in den notwendigen bereichen mit zusätzlicher helligkeit .

akzentuierte beleuchtung im bad und esszimmer durch passende pendelleuchten .

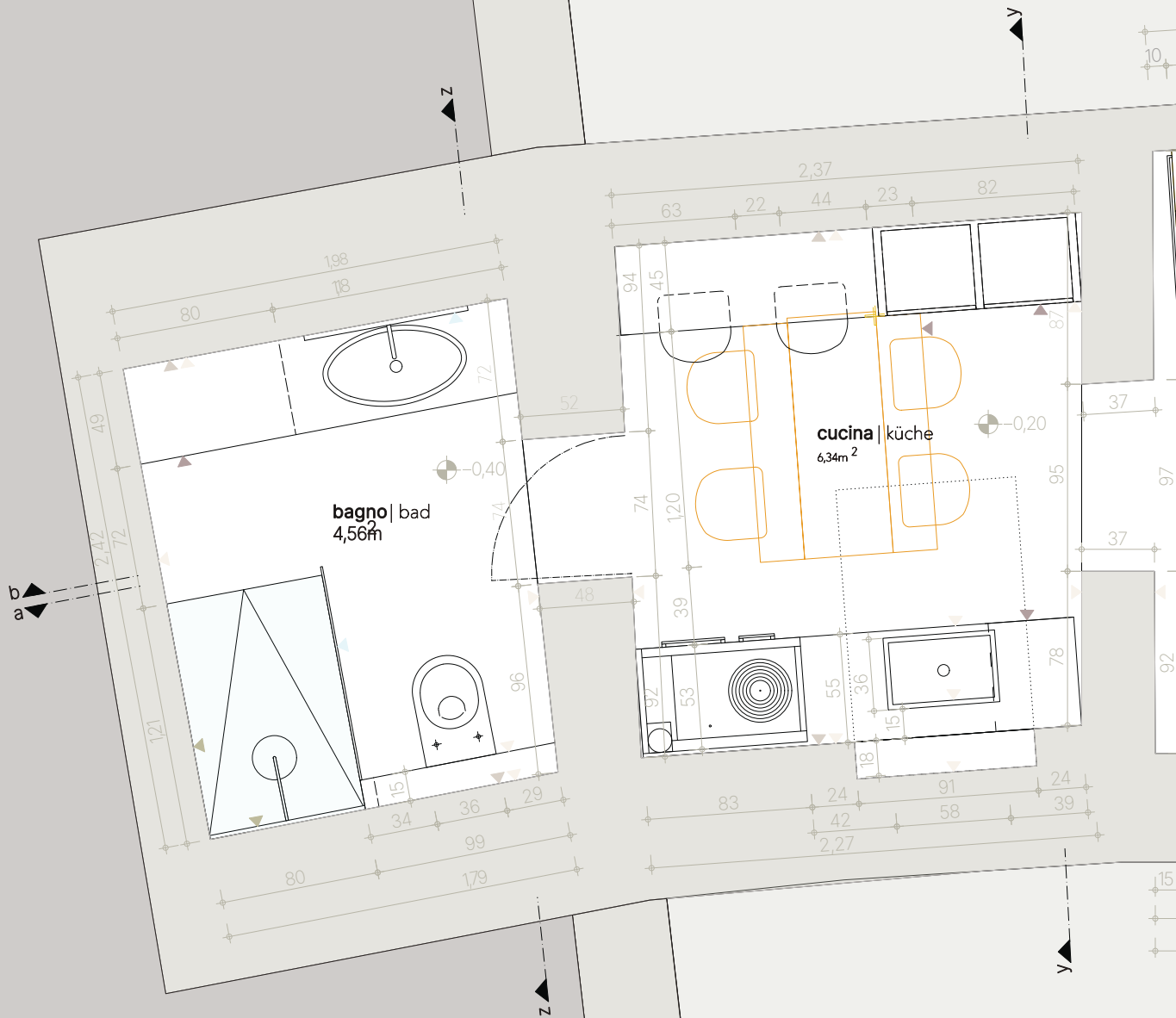

pianta | grundriss

m 1:33

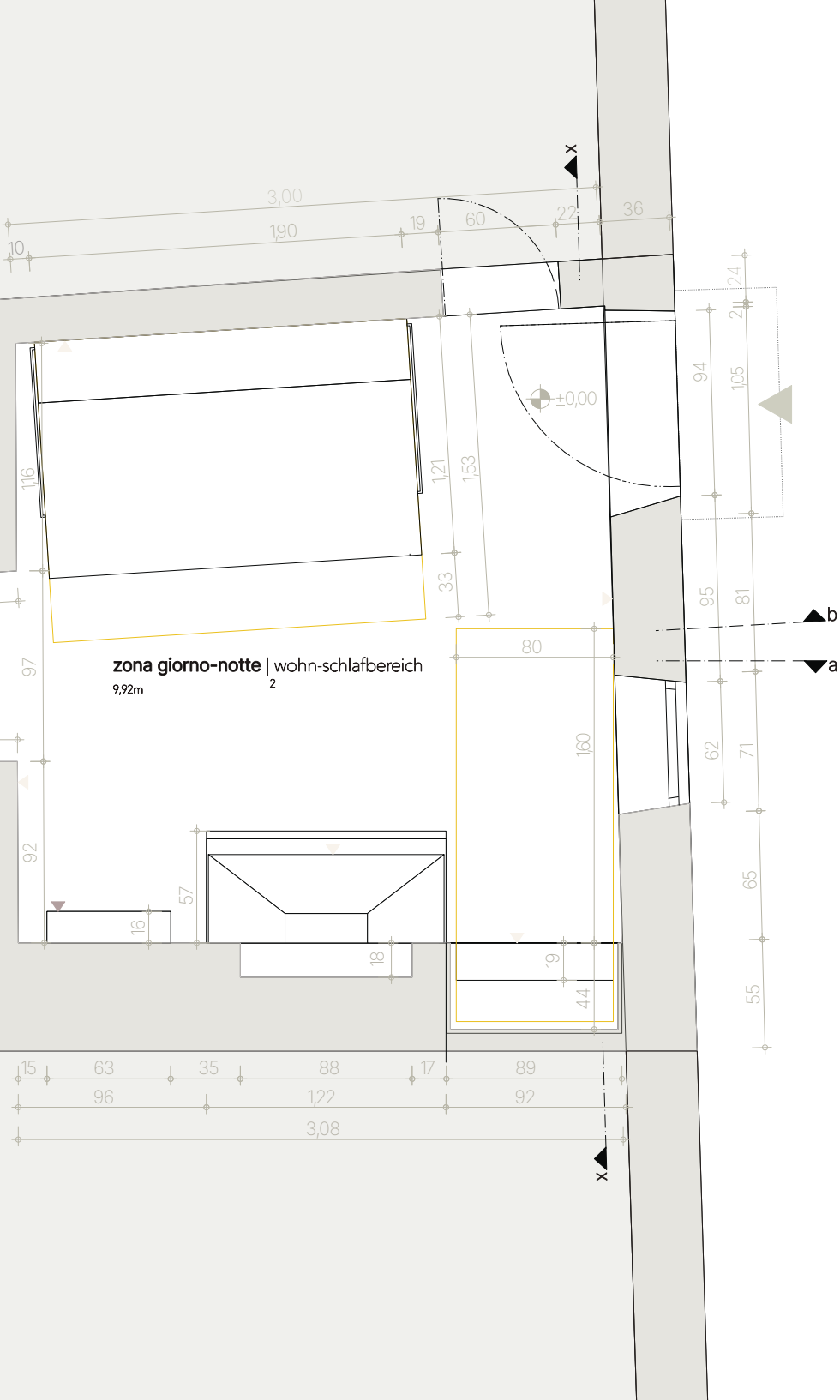

- calcare ▼ kalkstein
- intonaco di calce ▼ kalkputz
- pavimento in pietra naturale ▼ natursteinboden
- legno vecchio ▼ altholz
- piastrelle ▼ fliesen
- ottone ▼ messing
- vetro ▼ glas

sezione longitudinale a-a

längsschnitt a-a

m 1:50



- calcare ▼ kalkstein
- intonaco di calce ▼ kalkputz
- pavimento in pietra naturale ▼ natursteinboden
- legno vecchio ▼ altholz
- piastrelle ▼ fliesen
- ottone ▼ messing
- vetro ▼ glas

Il letto a scomparsa offre ulteriore spazio per dormire

murphy bett ermöglicht weitere schlafmöglichkeit

l'utilizzo di una cassetta per il controllo dell'inquinamento atmosferico

einsatz einer kaminkassette zur luftreinigung

stiva per stoviglie con scolapiatti integrato

stauraum für geschirr mit integrierte abtropfäche

lucernario con elemento d'acqua

oberlicht mit wasserspiel

tubo aperto per l'approvvigionamento idrico

offene leitung für wasserzufuhr

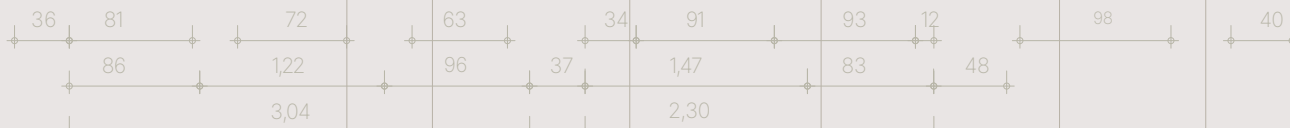

stoccaggio del legno
holzlager

segretario
sekretär

frigorifero integrato
integrierter kühlschrank

vecchia stufa in legno integrata in cucina
alter holzherd integriert in küche

wc e bidet combinato
wc und bidet kombi

pendenza del 2,5% per drenaggio dell'acqua
2,5% gefälle für wasserablauf

tavolo da pranzo con funzione
girevole e piano d'appoggio
ribaltabile

esstisch mit drehfunktion
und ausklappbarer tischplatte

Il letto a scomparsa
offre ulteriore spazio
per dormire

murphy bett
ermöglicht weitere
schlafmöglichkeit

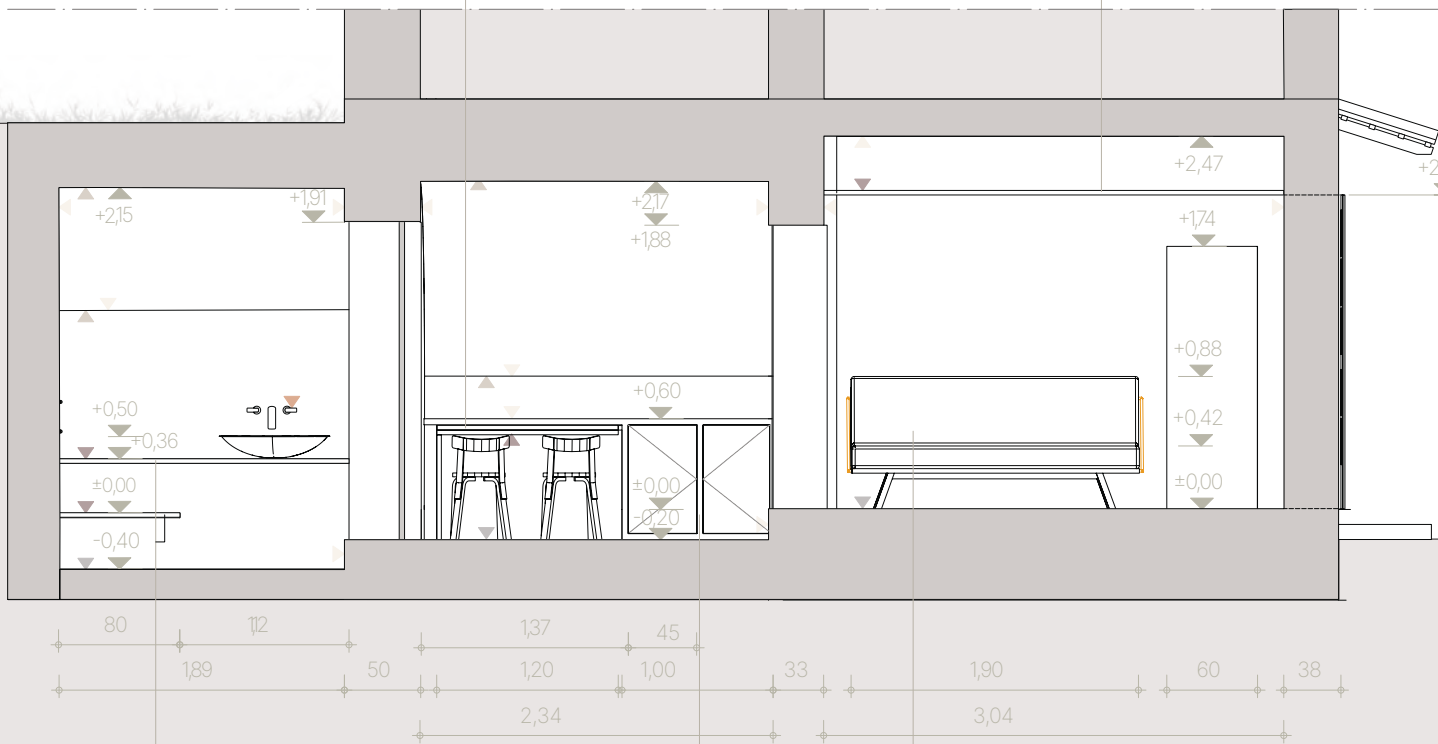

lavabo con ripiano
aggiuntivo

waschtisch
mit zusätzlicher
ablage

credenza integrata
con spazio di
archiviazione

integriertes
sideboard mit
stauraum

divano
possibilità di dormire
per due persone

klappsofa
schlafmöglichkeit
für zwei personen

sezione longitudinale b - b

längsschnitt b - b

m 1:50

ca
zio



- calcare ▼ kalkstein
- intonaco di calce ▼ kalkputz
- pavimento in pietra naturale ▼ natursteinboden
- legno vecchio ▼ altholz
- piastrelle ▼ fliesen
- ottone ▼ messing
- vetro ▼ glas

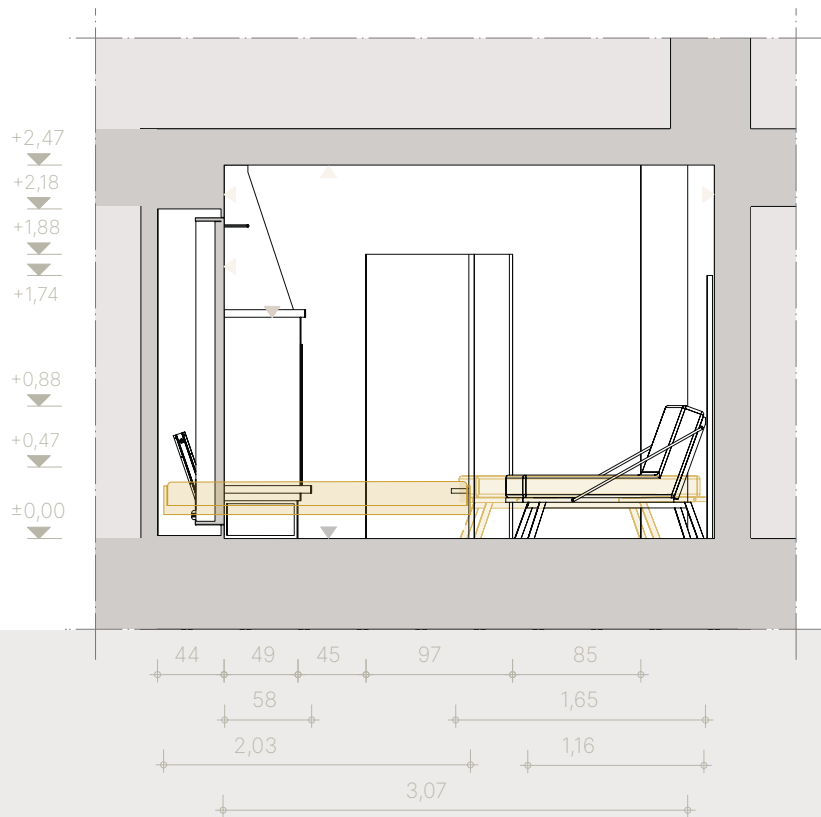

schnitt x-x
zona giorno-notte | wohn-schlafbereich

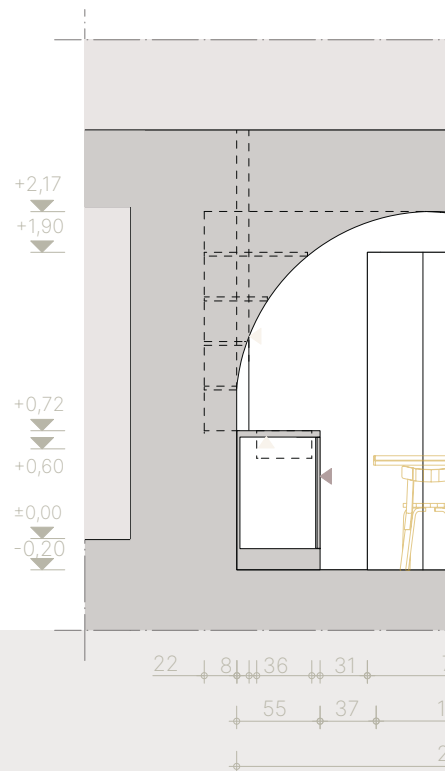

schnitt y-y
cucina | küche

sezioni spaccate

querschnitte

m 1:50

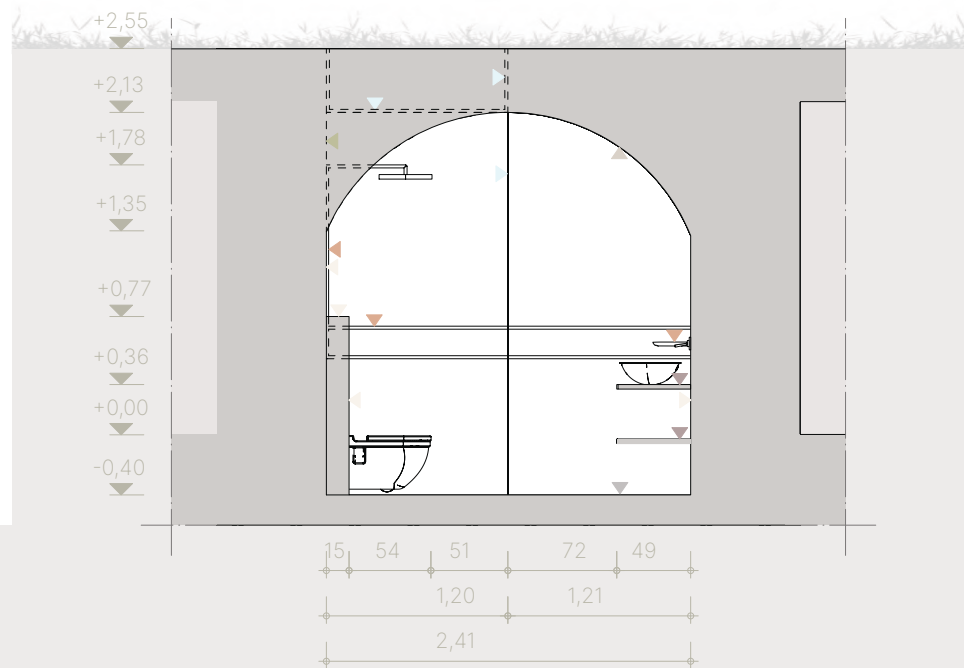
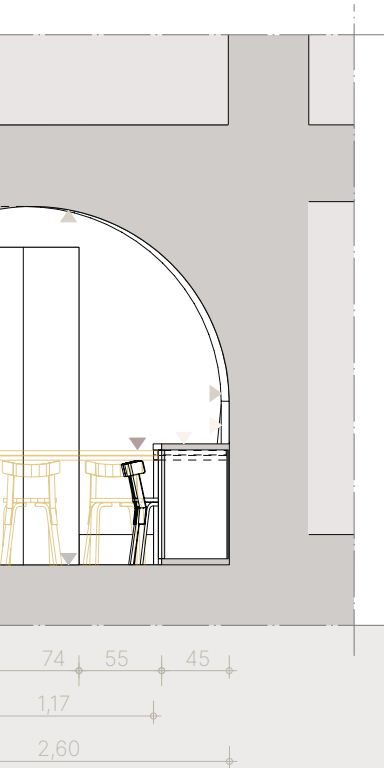

schnitt z-z
bagno | bad

- calcare ▼ kalkstein
- intonaco di calce ▼ kalkputz
- pavimento in pietra naturale ▼ natursteinboden
- legno vecchio ▼ altholz
- piastrelle ▼ fliesen
- ottone ▼ messing
- vetro ▼ glas



zona giorno-notte | wohn-schlafbereich

cucina | küche



bagno | bad

trinità | il rifugio di stefano basevi

Projekt 1 | INN B6 | SoSe 2023

Giulia Kaubisch
Stine Volk

Prof. Denise Dih

Un progetto con Stefano Basevi

Technische Hochschule Rosenheim
Fakultät für Innenarchitektur, Architektur und Design (IAD)

www.th-rosenheim.de

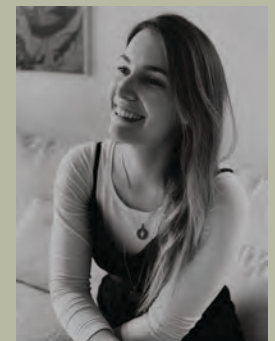





giulia kaubsich & stine volk

