

RAUM KRAFT KONSTRUKTION

El Lissitzky – Proun 6

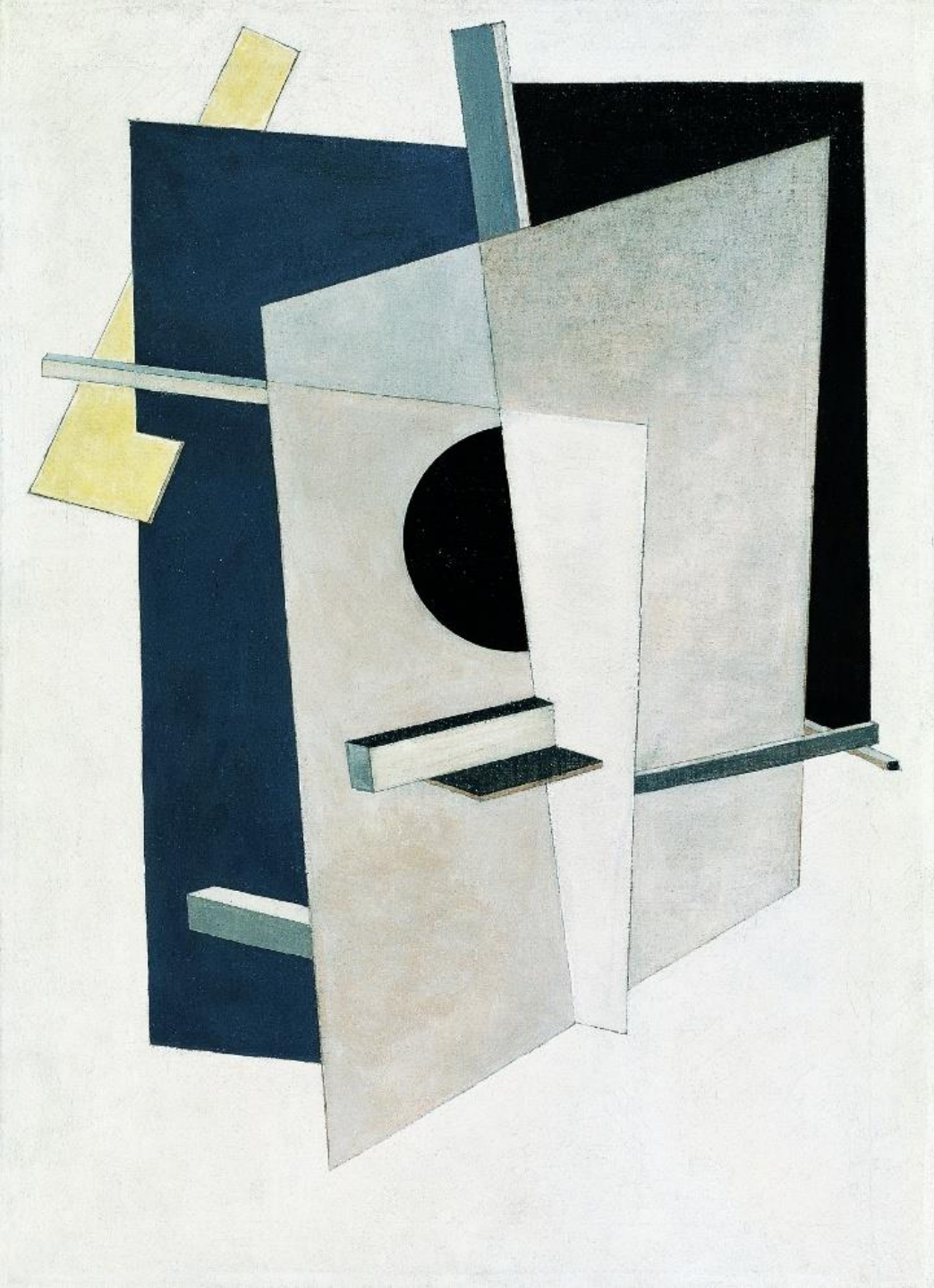

Proun 6

Proun ist ein Akronym für Pro-Unovis (Projekt für die Verfechtung des Neuen)

Unovis war eine Künstlergruppe, der Lissitzky angehörte

Er versucht einen leeren Raum zu schaffen in dem die Formen und Körper schweben

Material/Technik: Öl auf Leimwand

Maße: 810x590mm



El Lissitzky

- * 23. November 1890 in Russland
- wollte an die Kunsthochschule in St Petersburg > als Jude abgelehnt
- ging nach Deutschland und studierte in Darmstadt Architektur und Ingenieurwissenschaften
- 1915 Abschluss Diplom in Moskau
- danach tätig in der Malerei, Architektur, Grafikdesign, Typografie und Fotografie
- > vielseitiger Künstler der Moderne
- Proun Reihe entstand in seiner Zeit der Studiums
- † 30. Dezember 1941



BILDANALYSE

El Lissitzky – Proun 6

FARBEN / LICHT

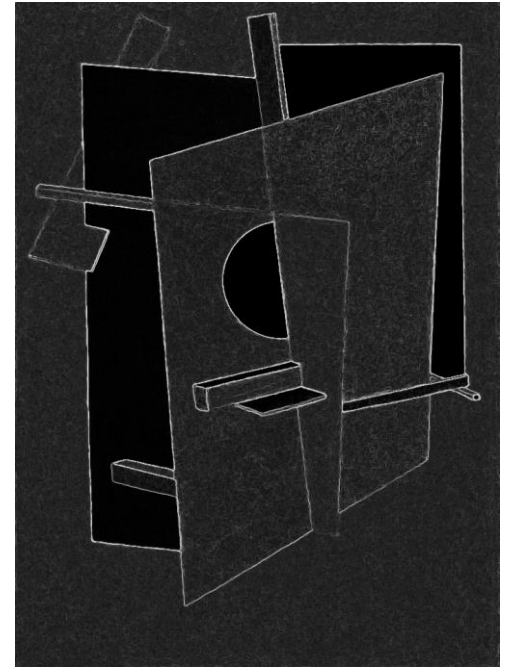
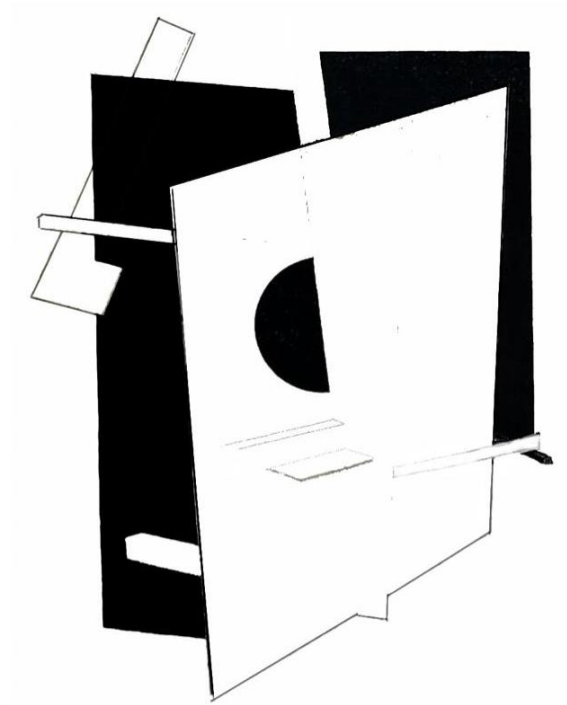

PERSPEKTIVEN

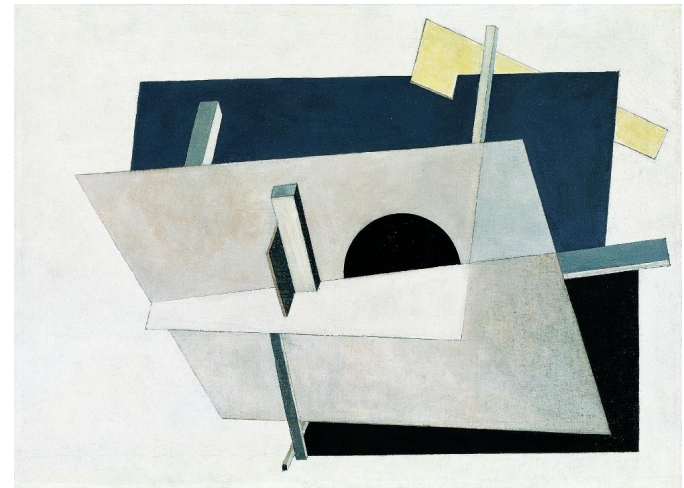
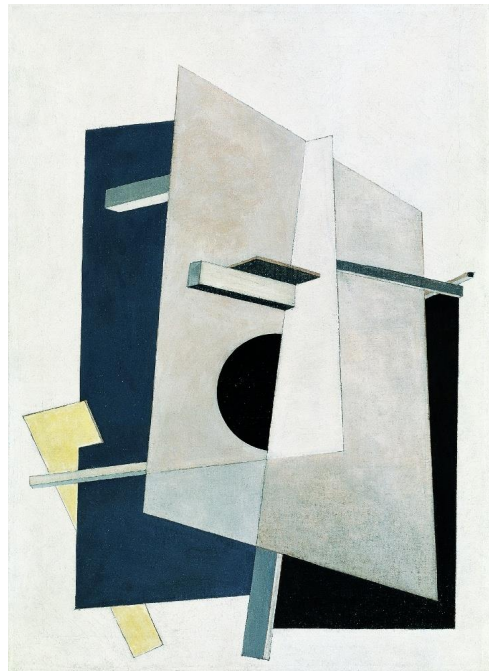
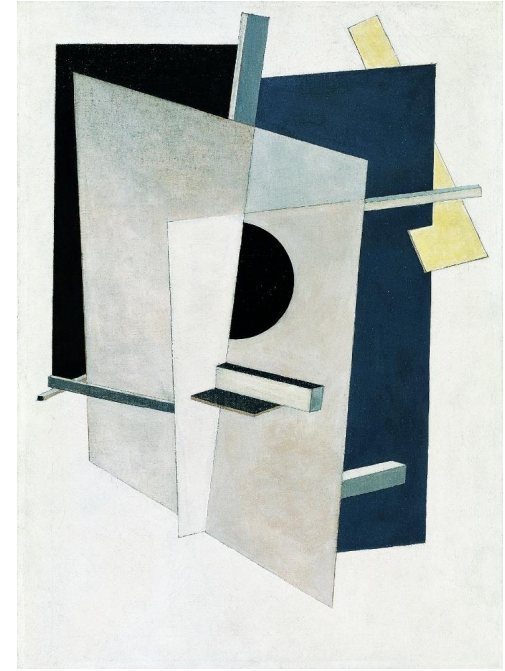
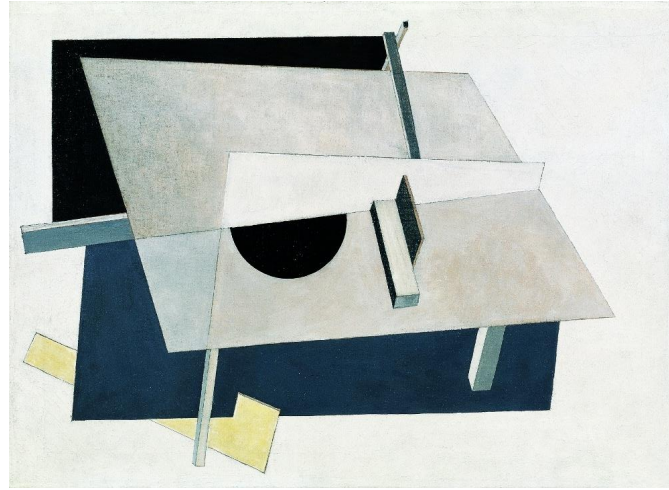

WINKEL

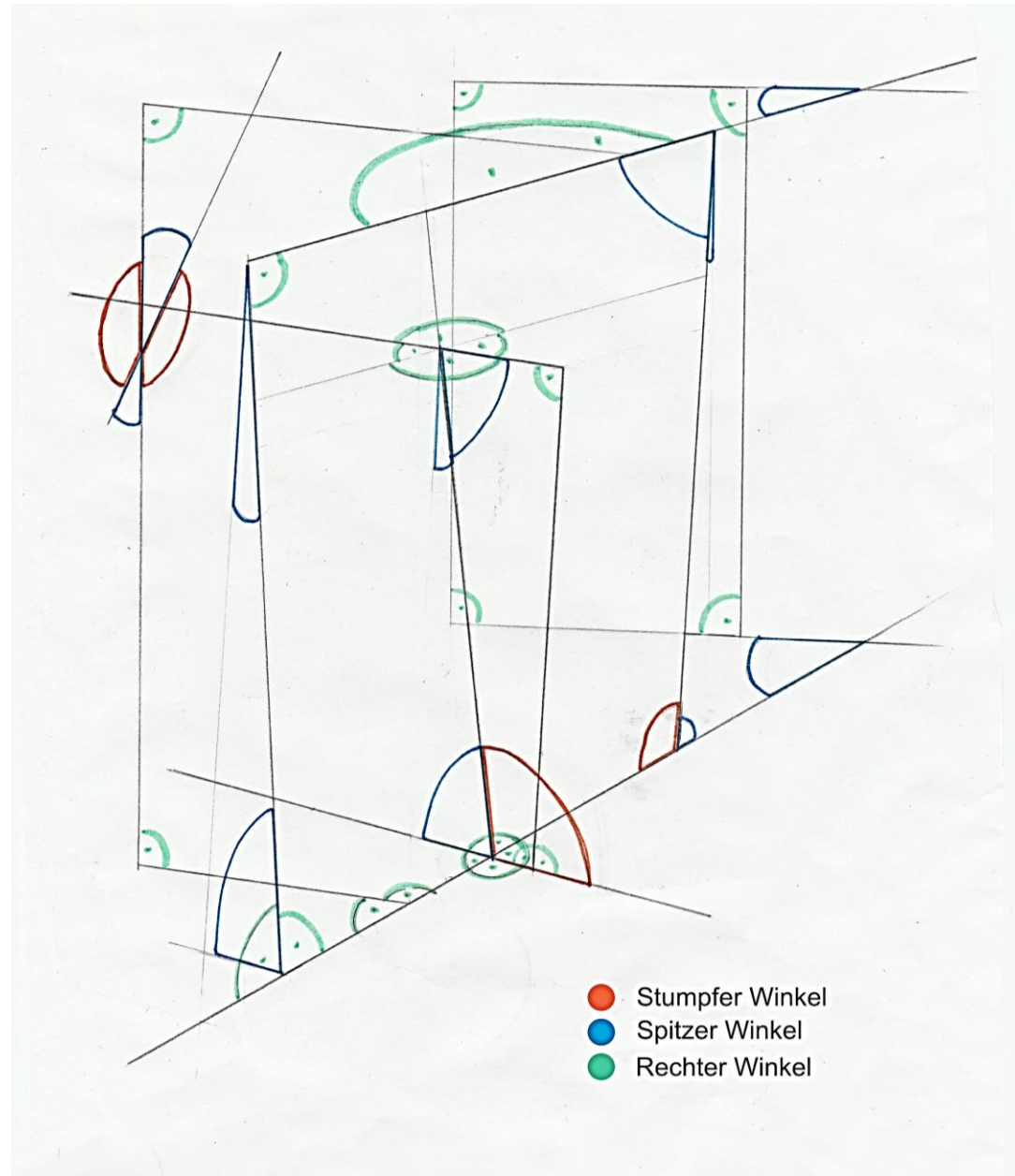
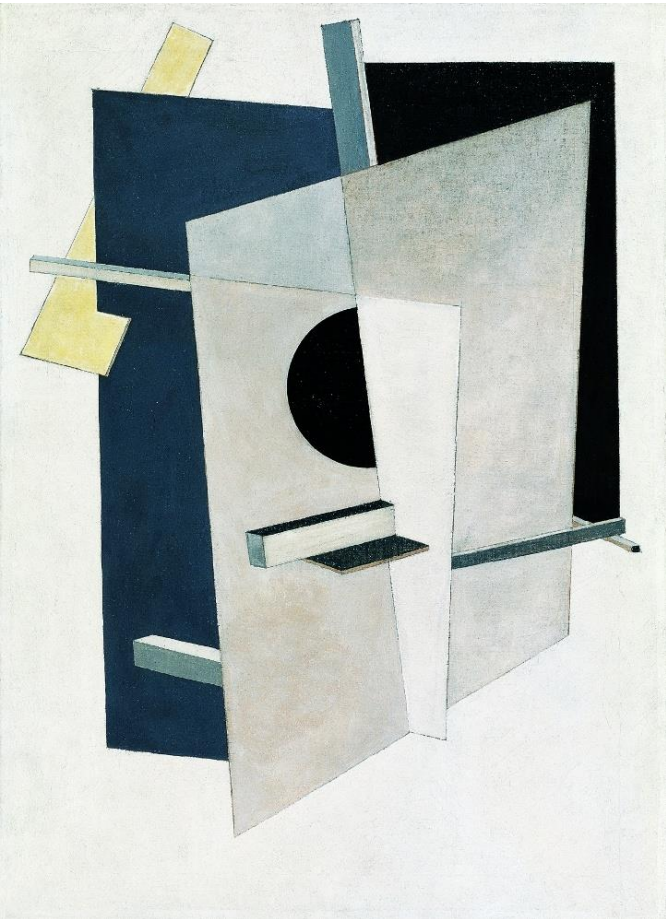

FLÄCHEN

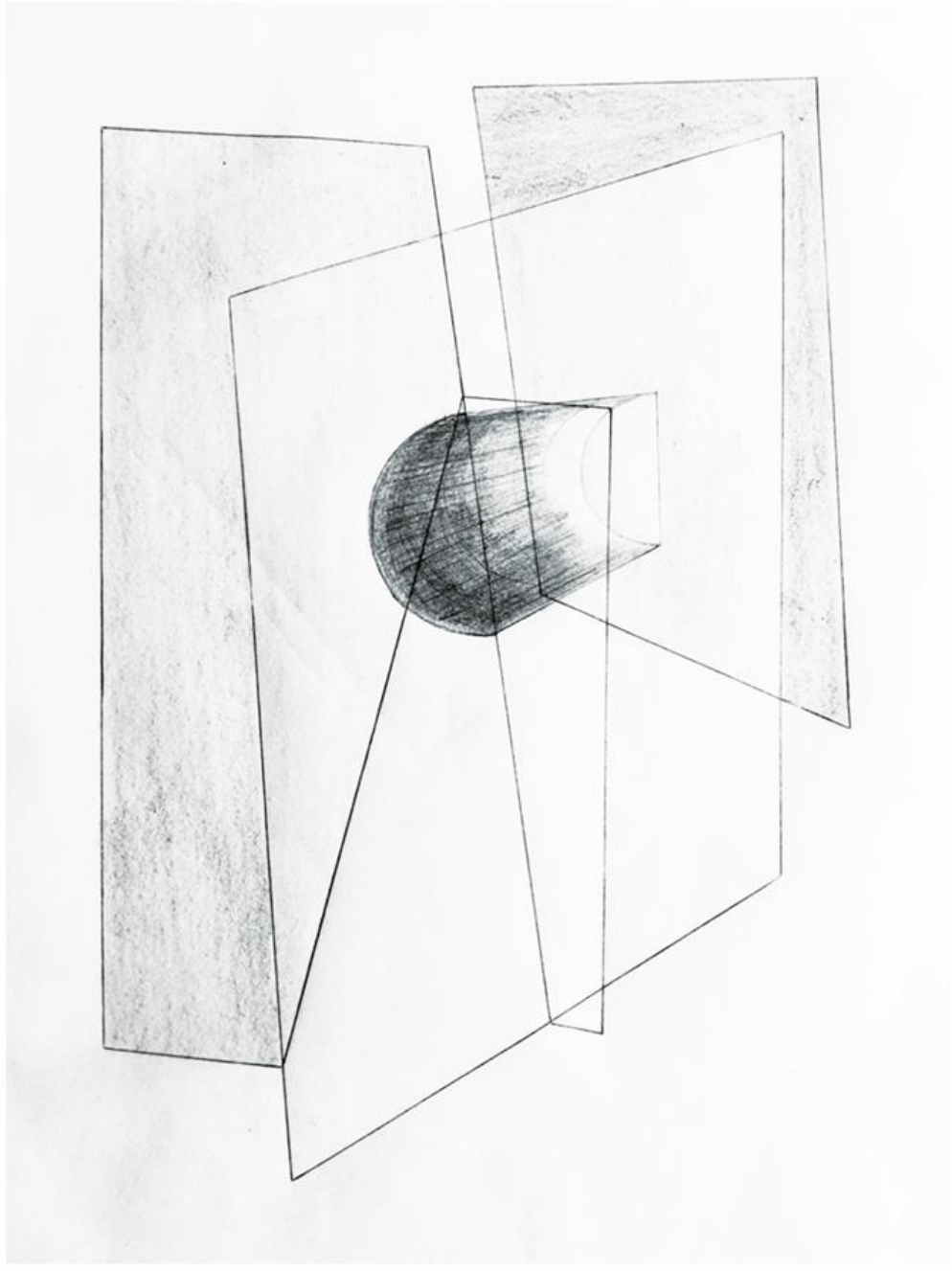
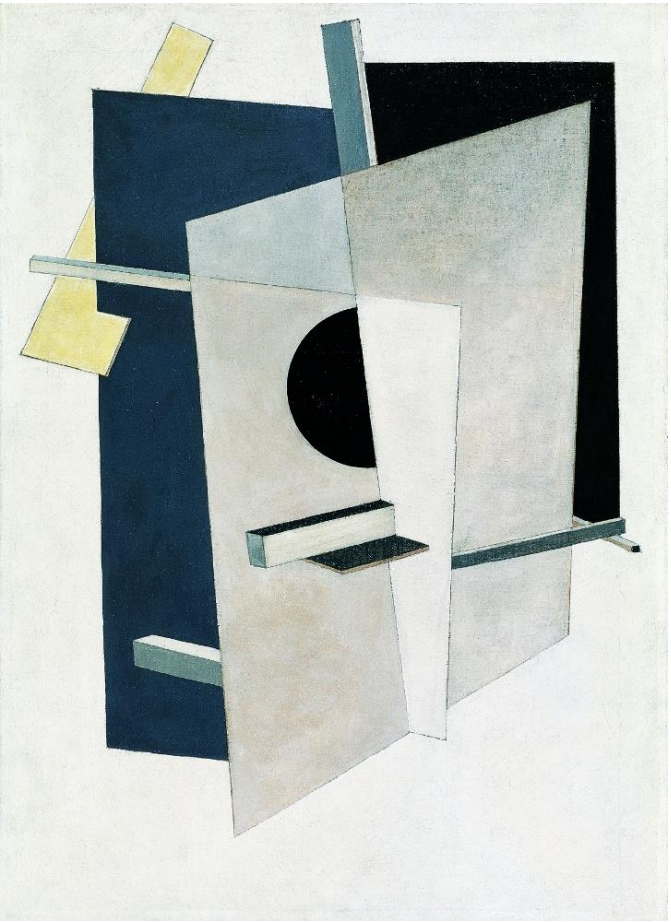

KÖRPER

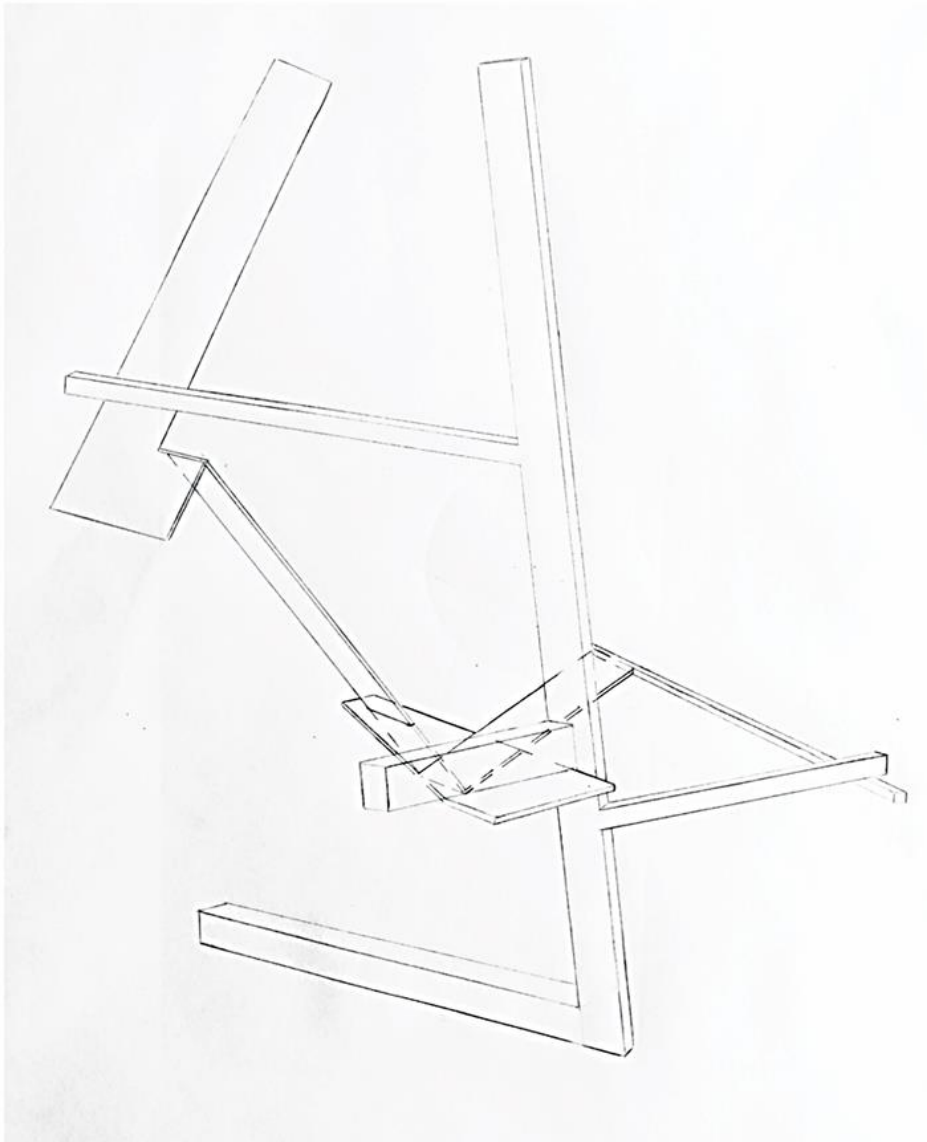

RAUM

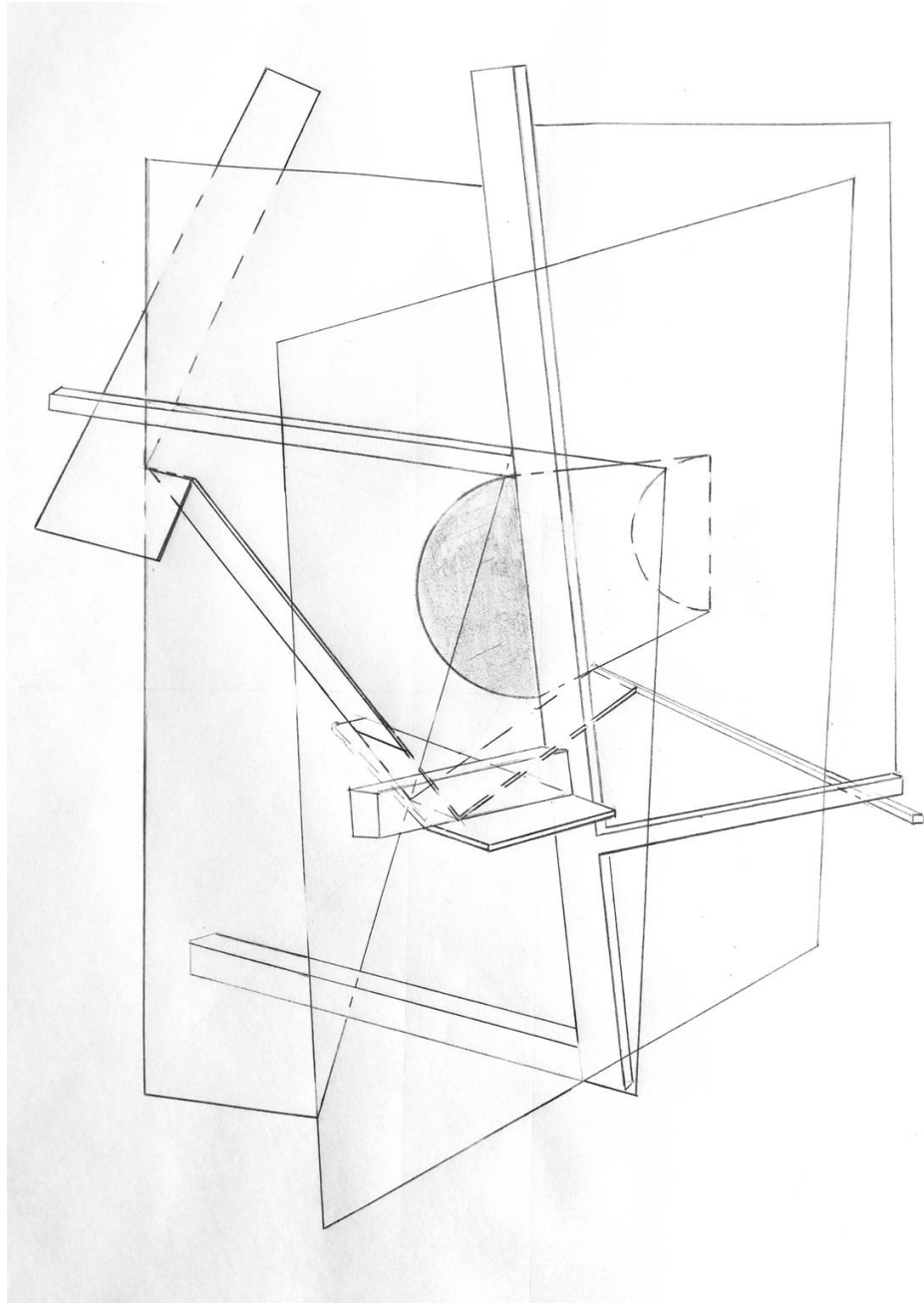

SPANNUNG

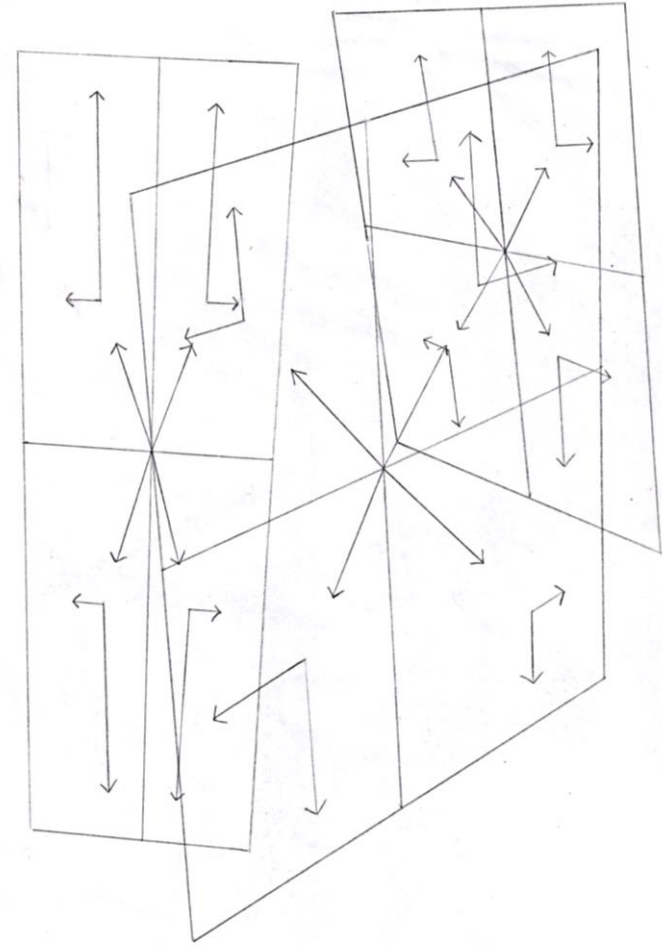
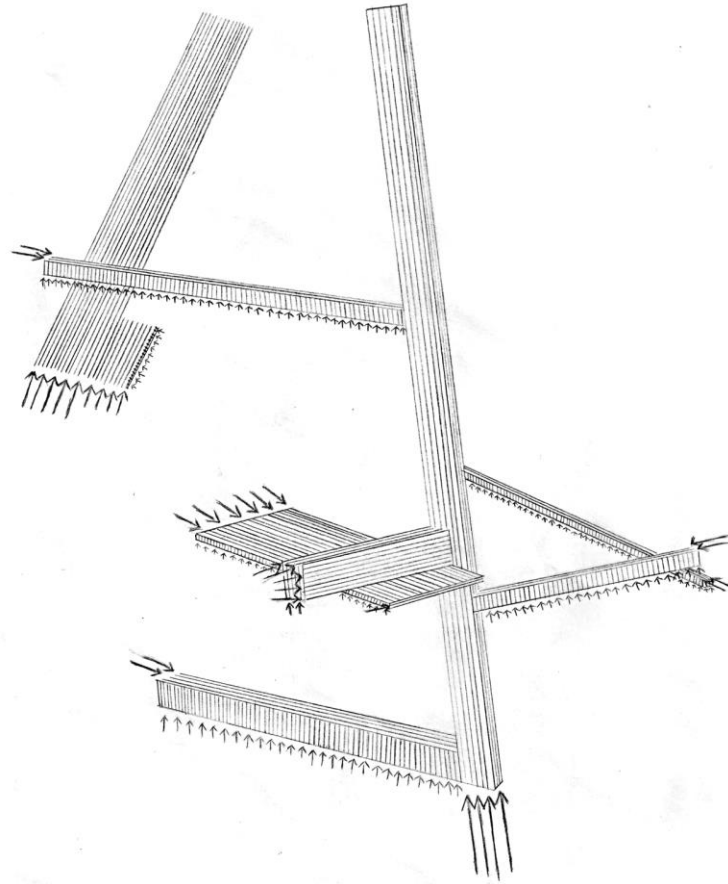

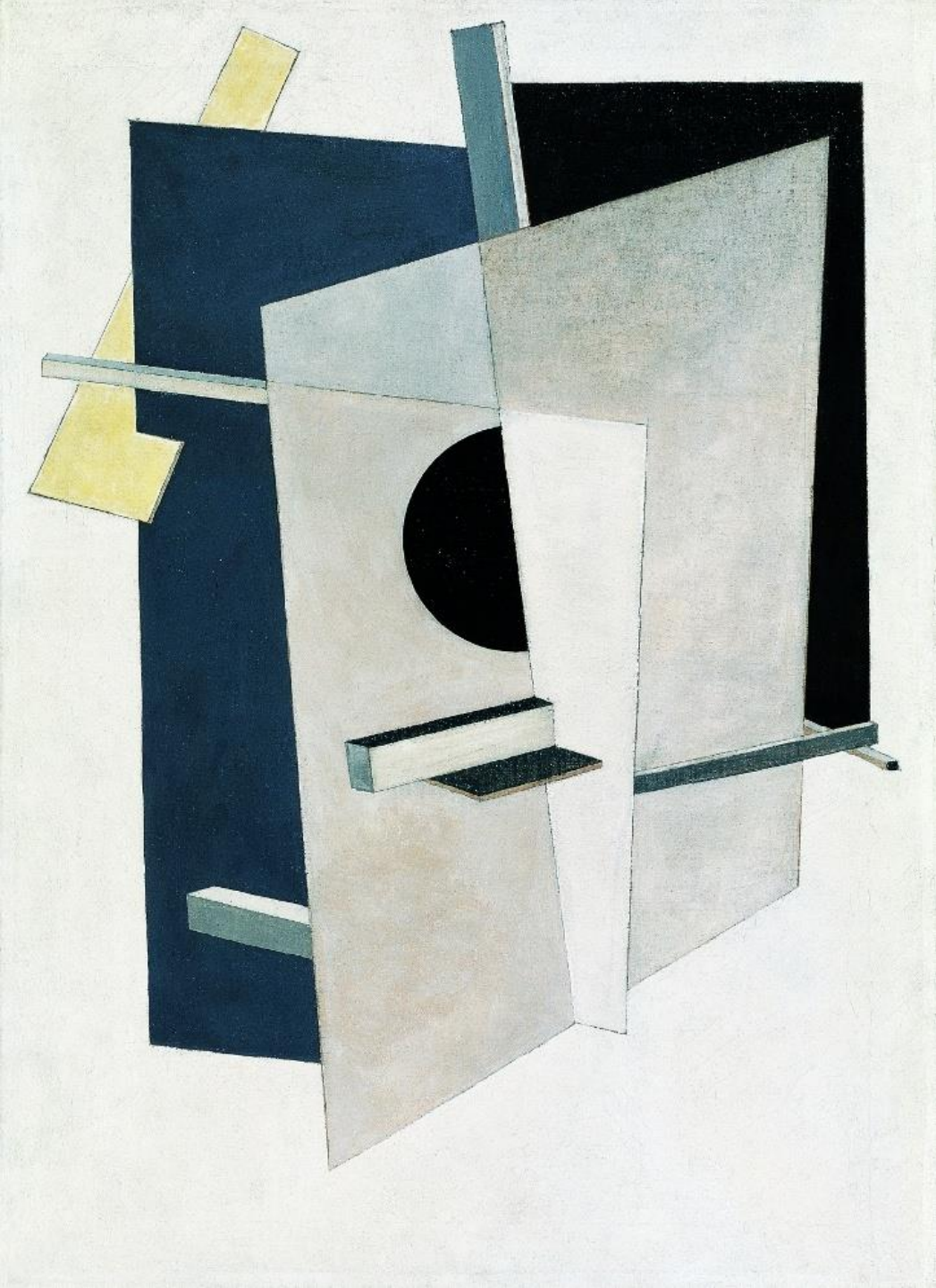

RELIEF

El Lissitzky – Proun 6



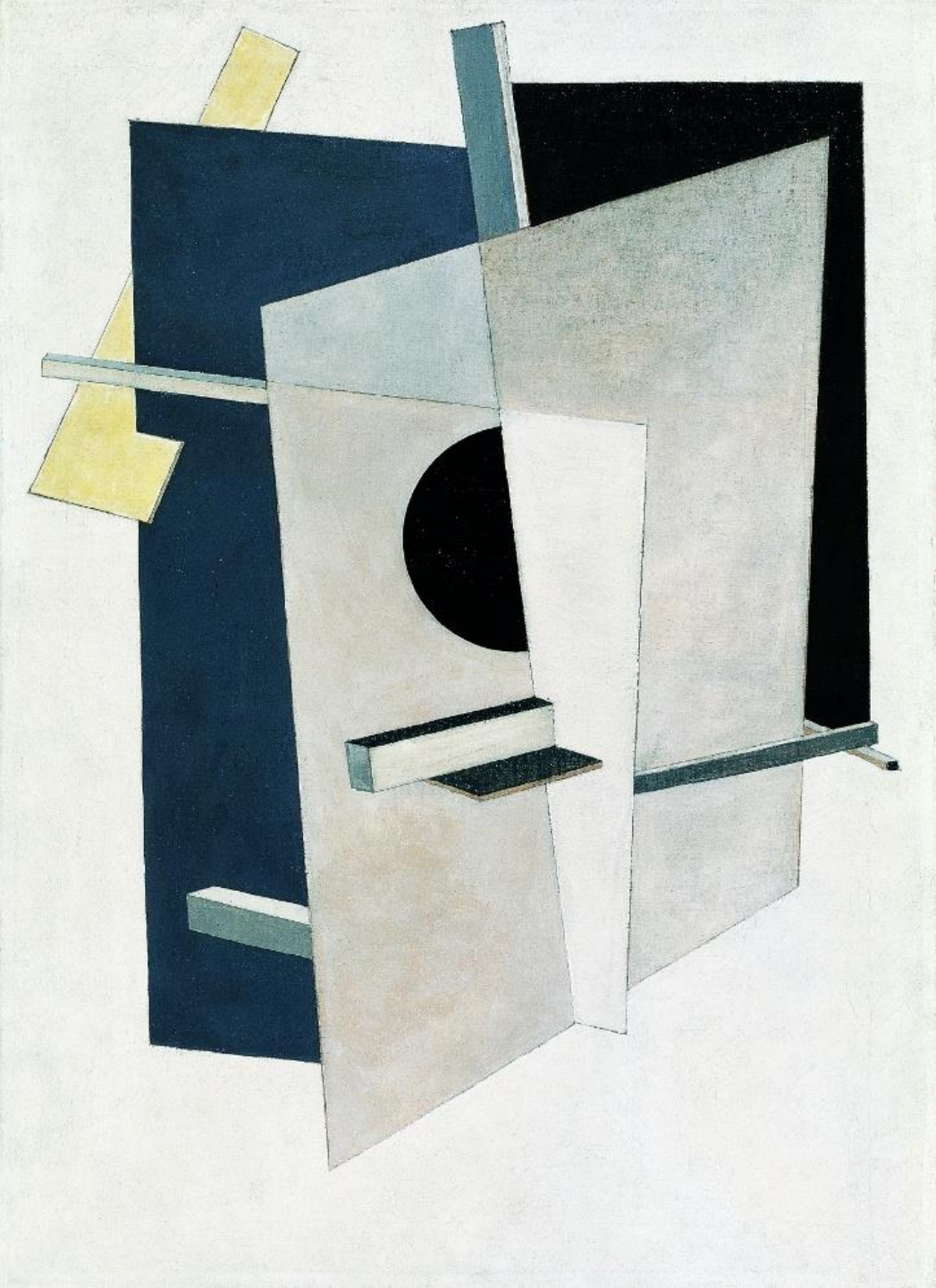

OBJEKT

El Lissitzky – Proun 6

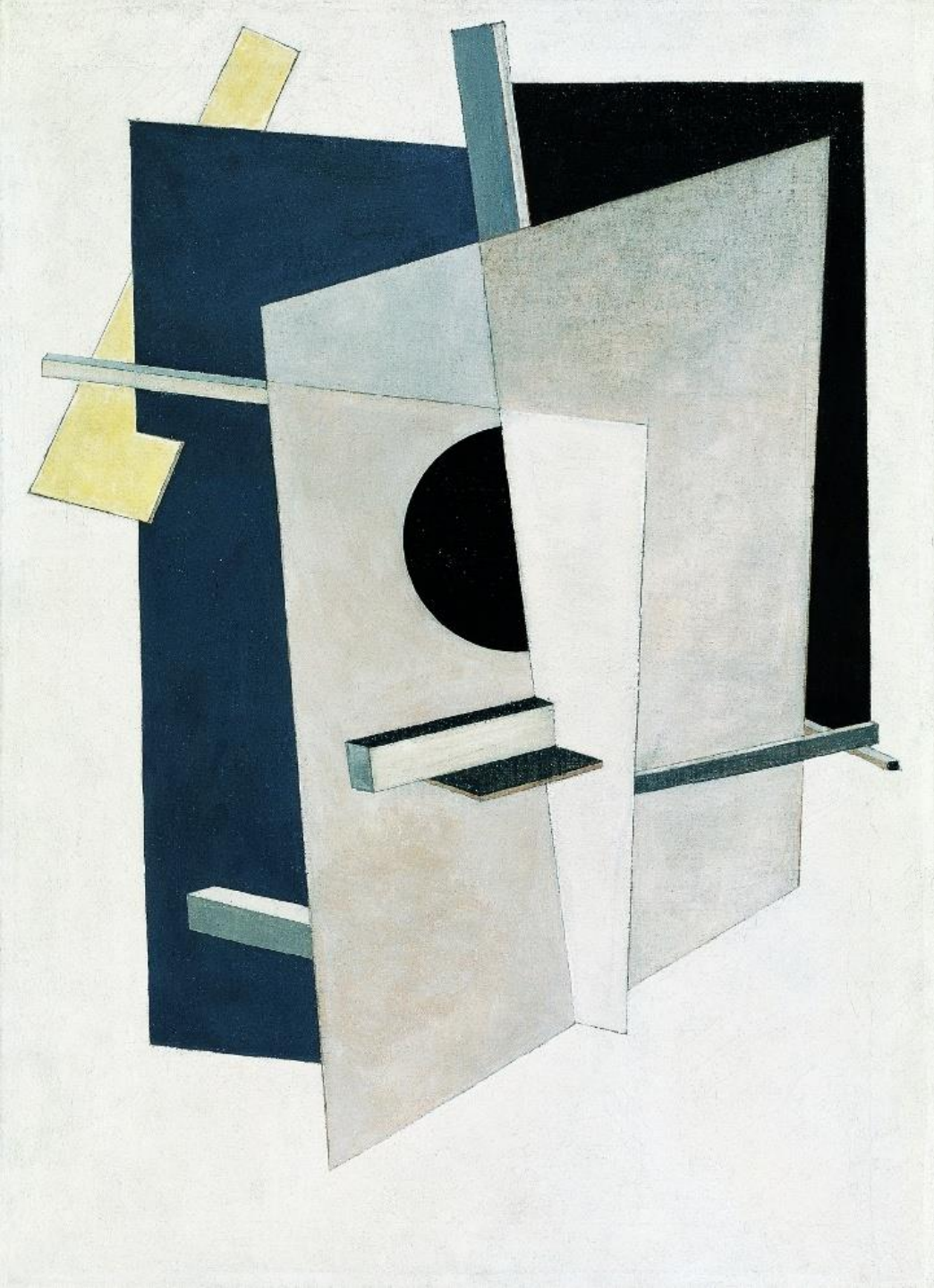

Erste Interpretation als Perpetuum Mobile

-helle Hintergrund suggeriert eine unendliche Weite

-Flächen als Konstrukt mit durchdringenden und drehenden Flächen

-über Zentralbalken alles miteinander verbunden der die Schwerelosigkeit der Flächen ermöglicht

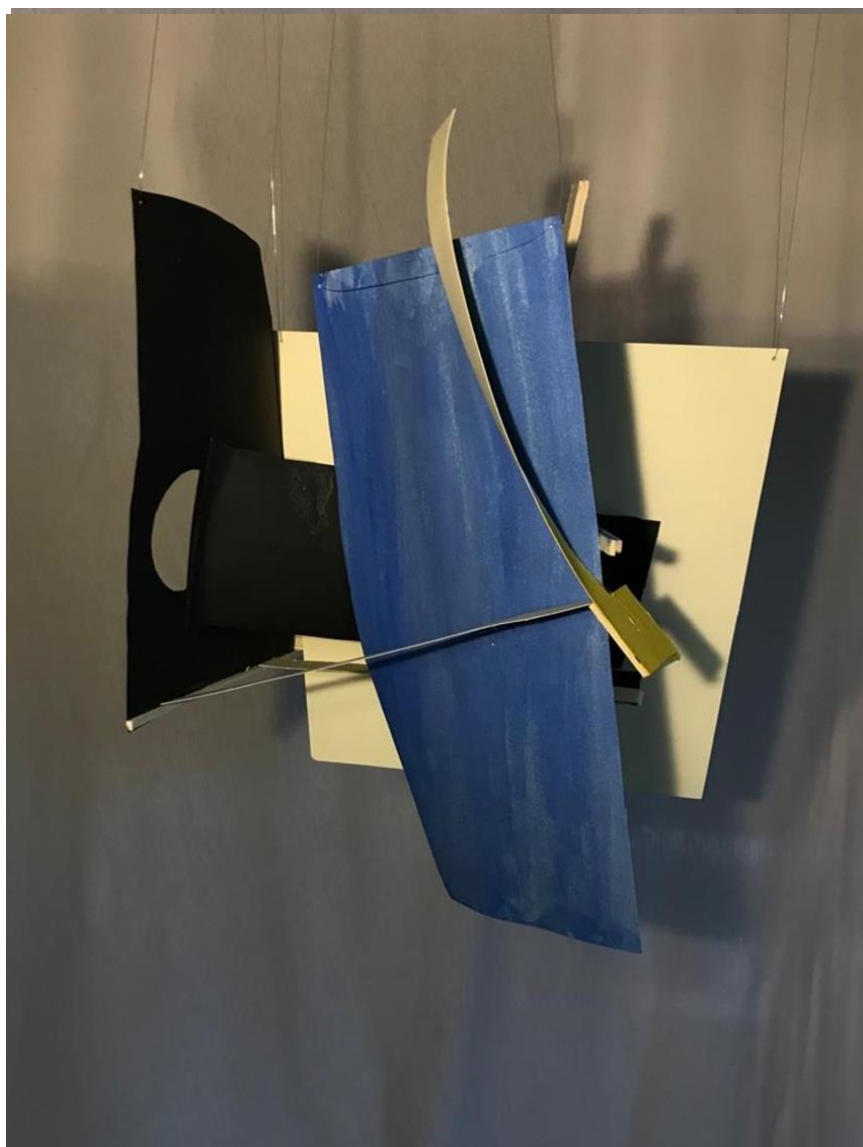
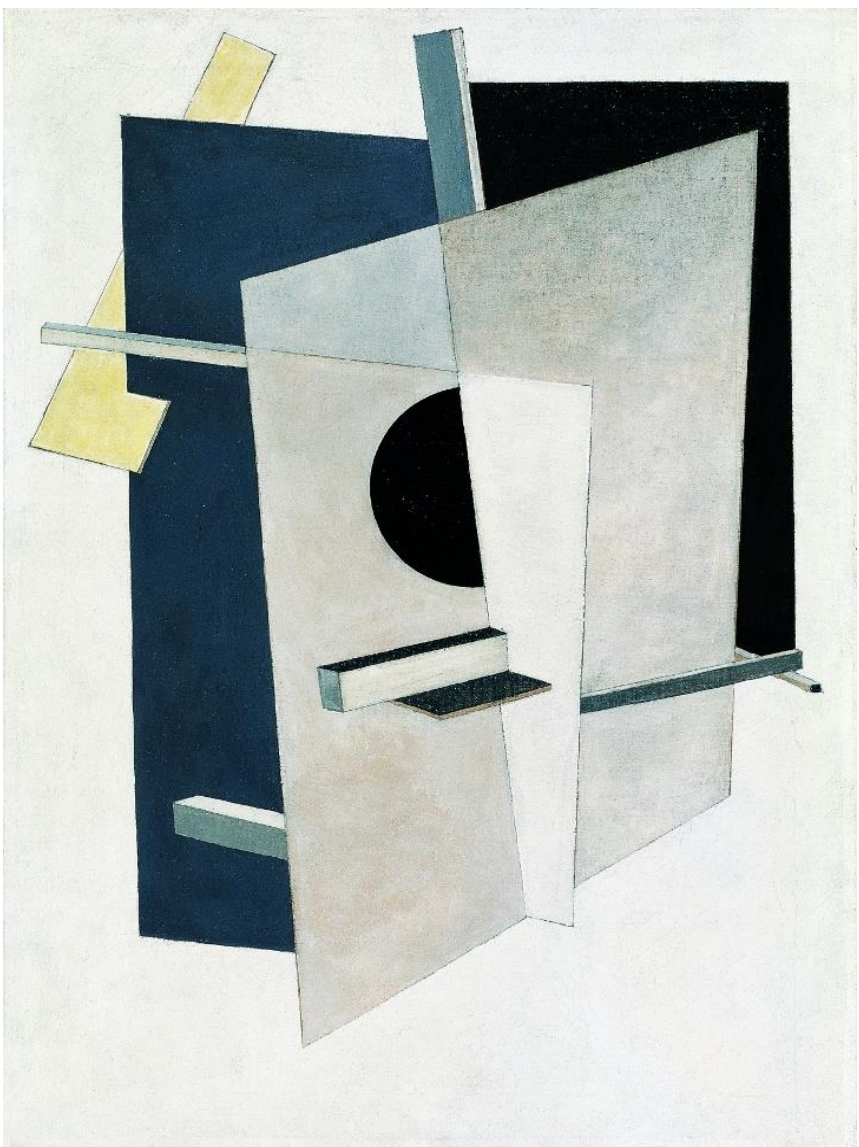

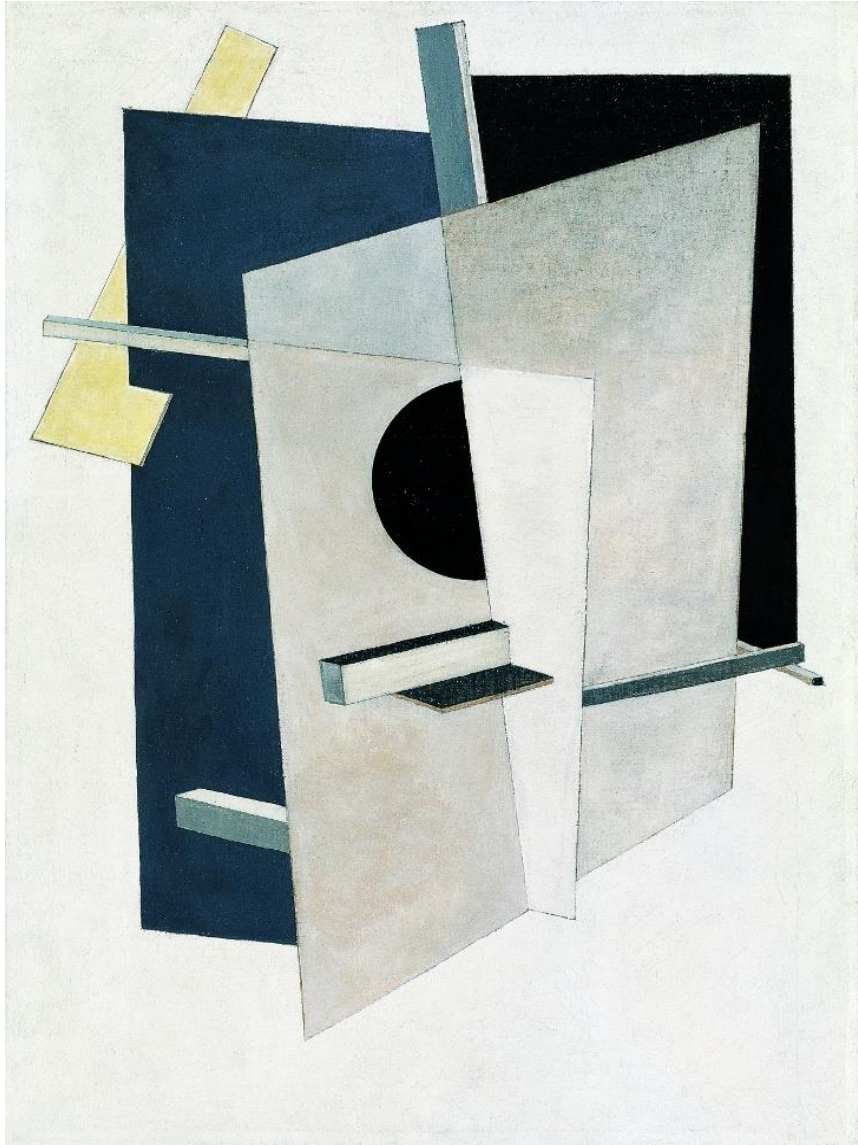

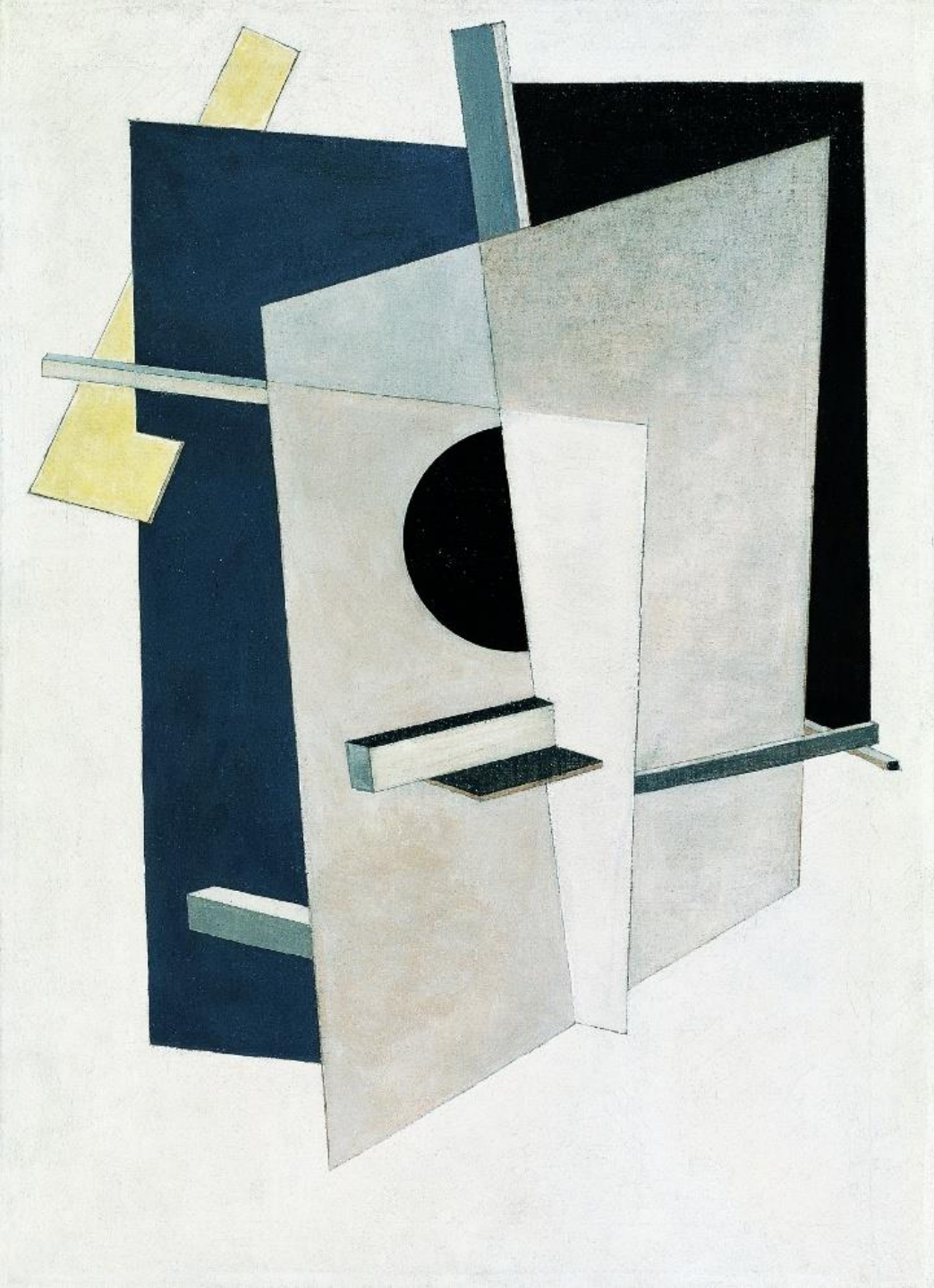

Interpretation als Sakralbau

-Schaffen eines Raumes ohne die Wirkung
des Bildes von El Lissitzky zu verfälschen

-Der sich aus den aneinanderlehenden
Flächen ergibt und ein Raumvolumen
erzeugt

-als stehendes Objekt auf einem
Untergrund der die Weite weiterhin
suggeriert

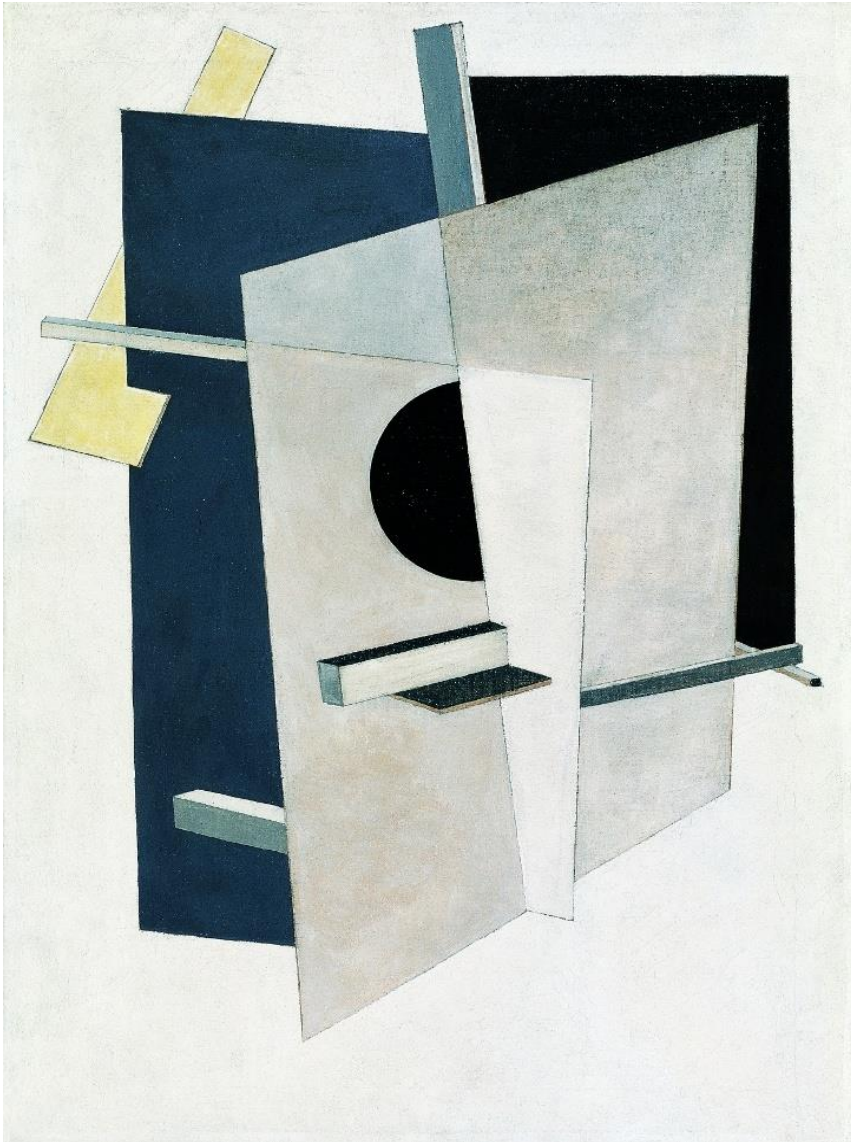

Erstes Modell des Sakralbauwerkes aus Karton

Proportionsanalyse

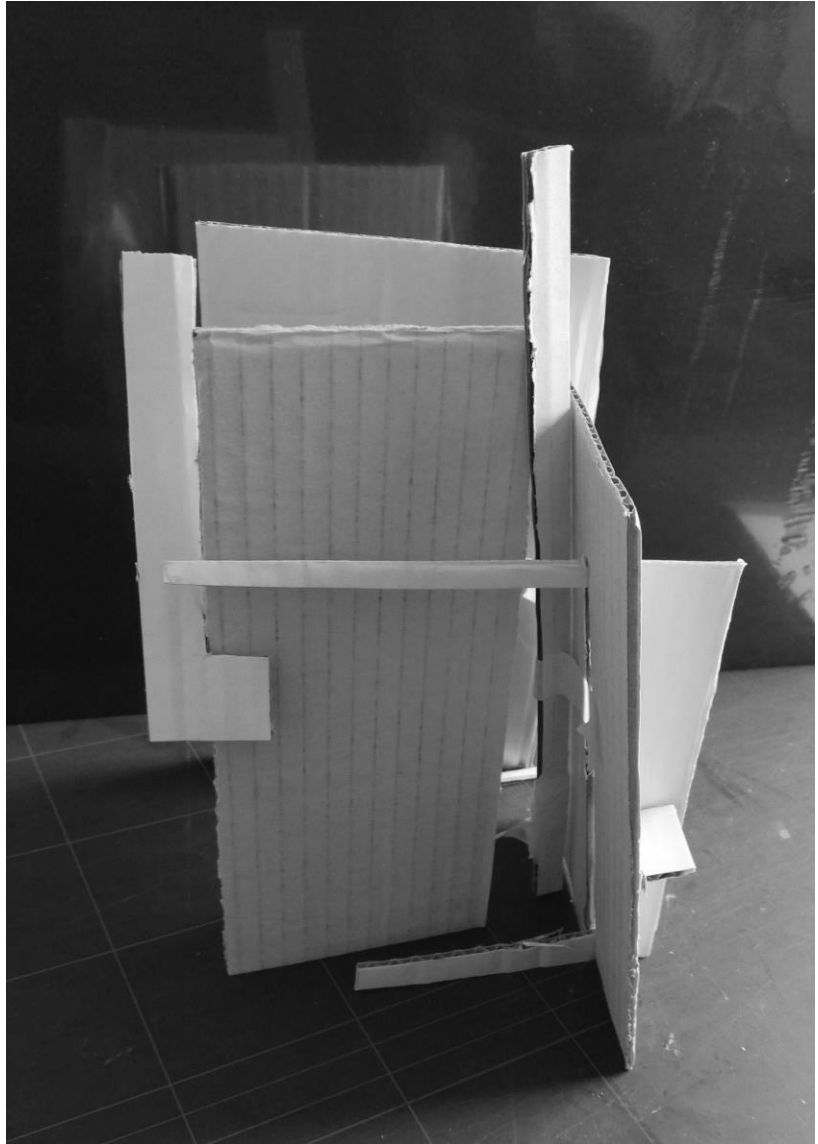
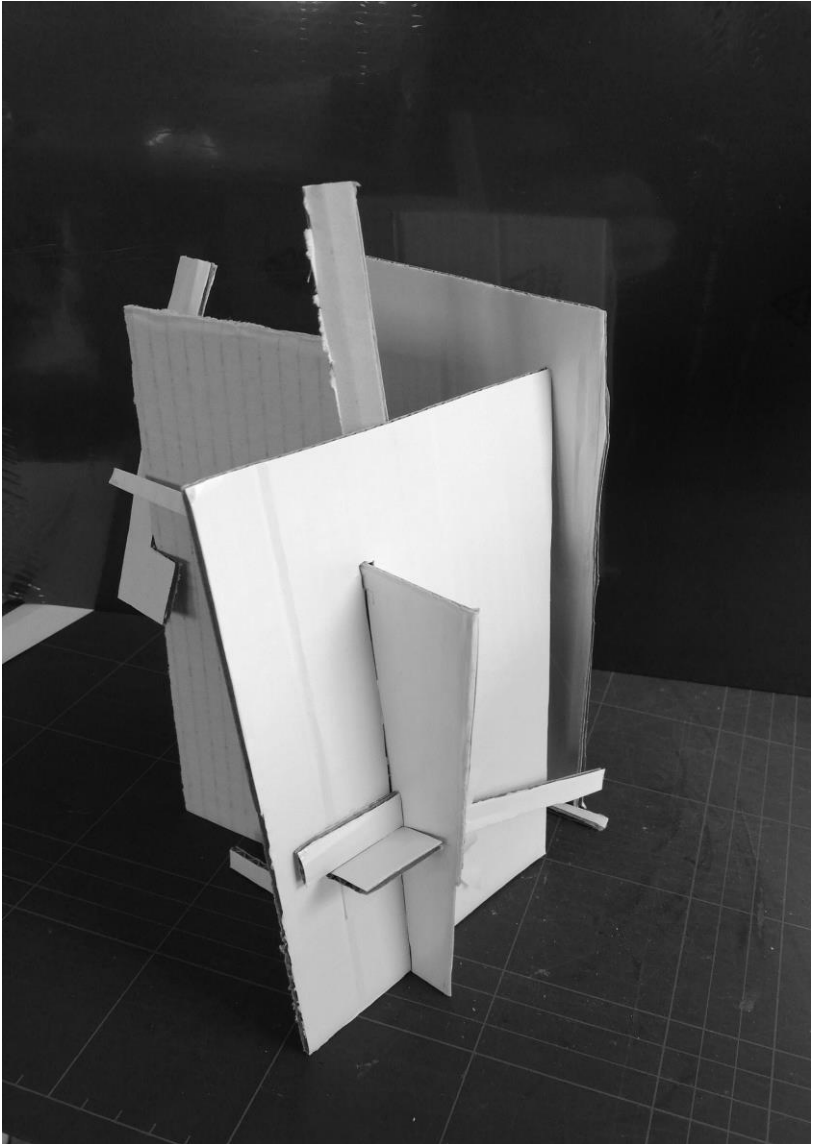

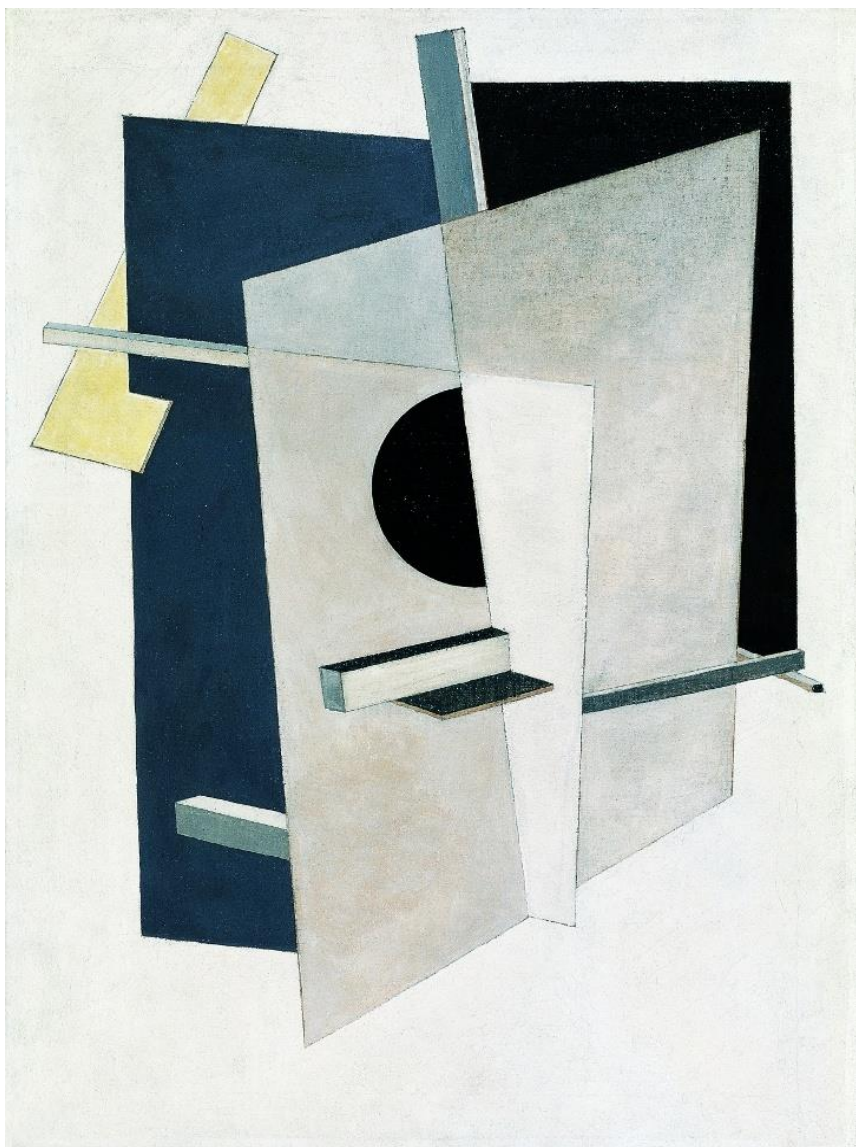

Endmodell des Sakralbauwerkes aus Finnpappe

Balken ebenso aus Finnpappe mehrschichtig
aneinander geklebt

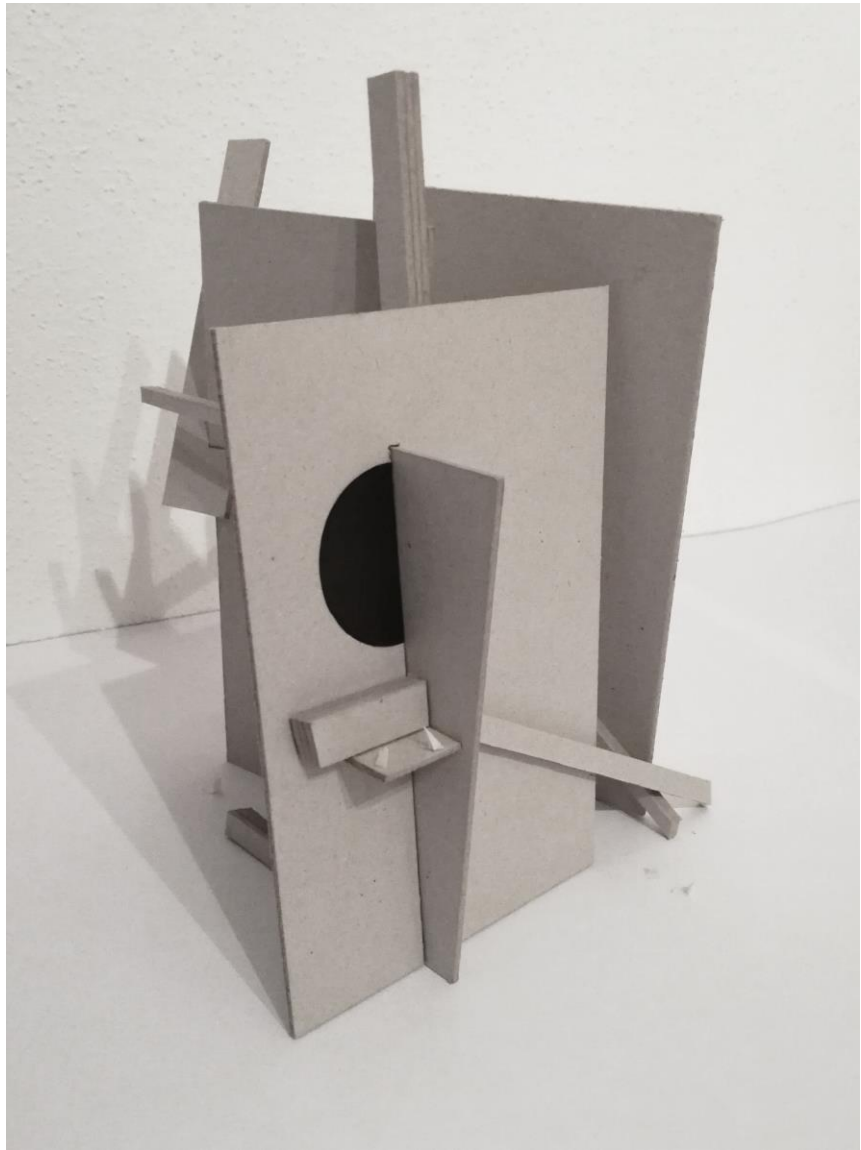
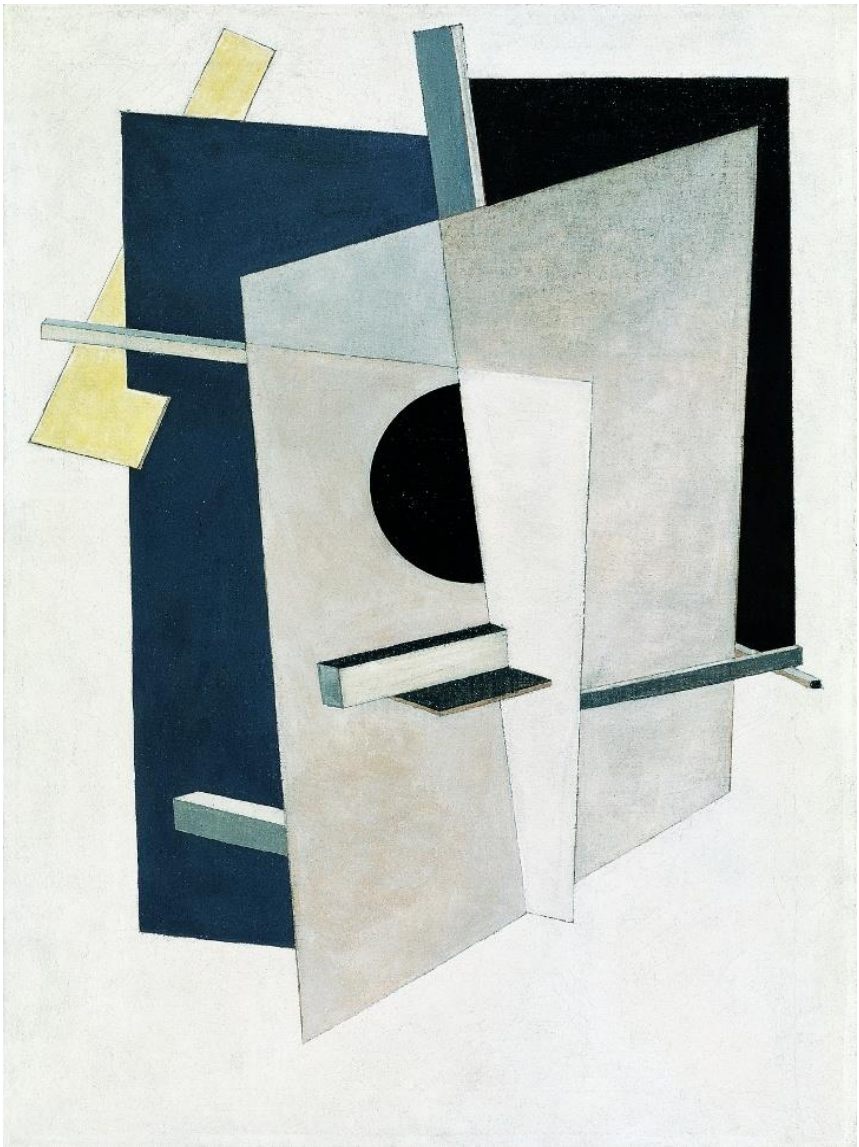

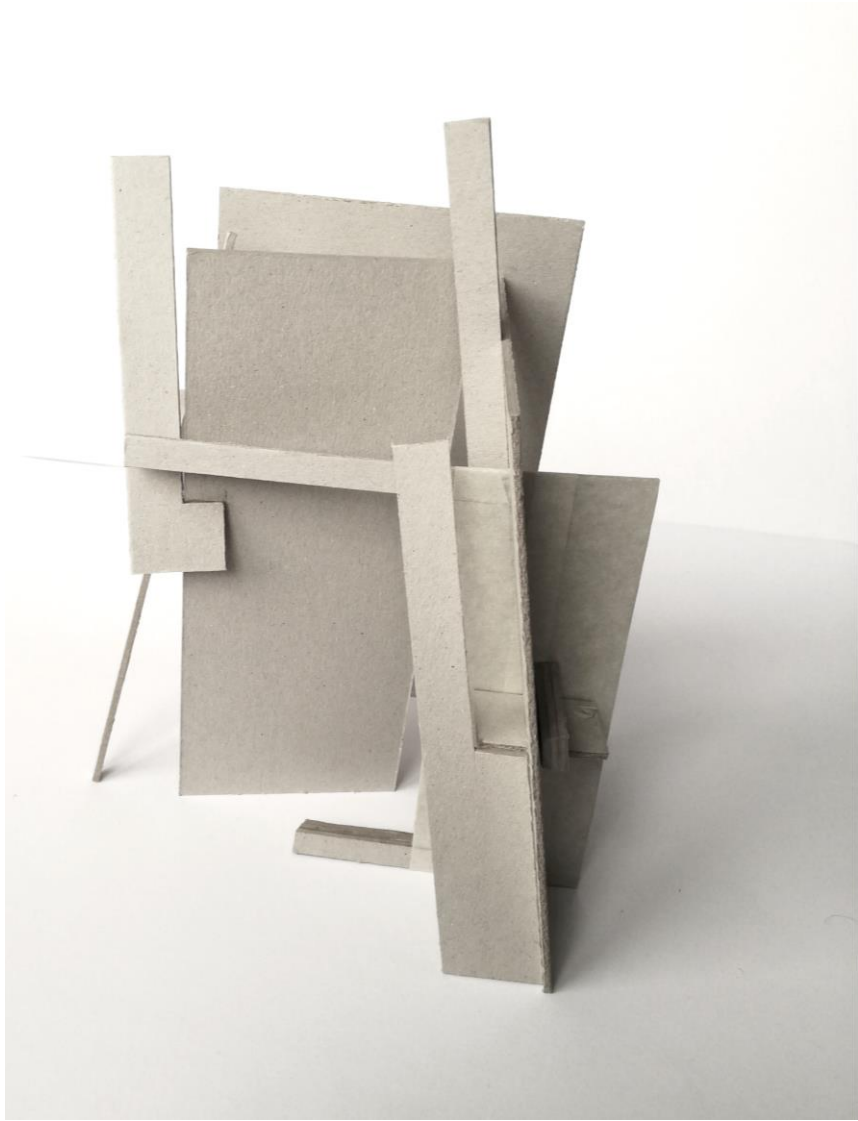

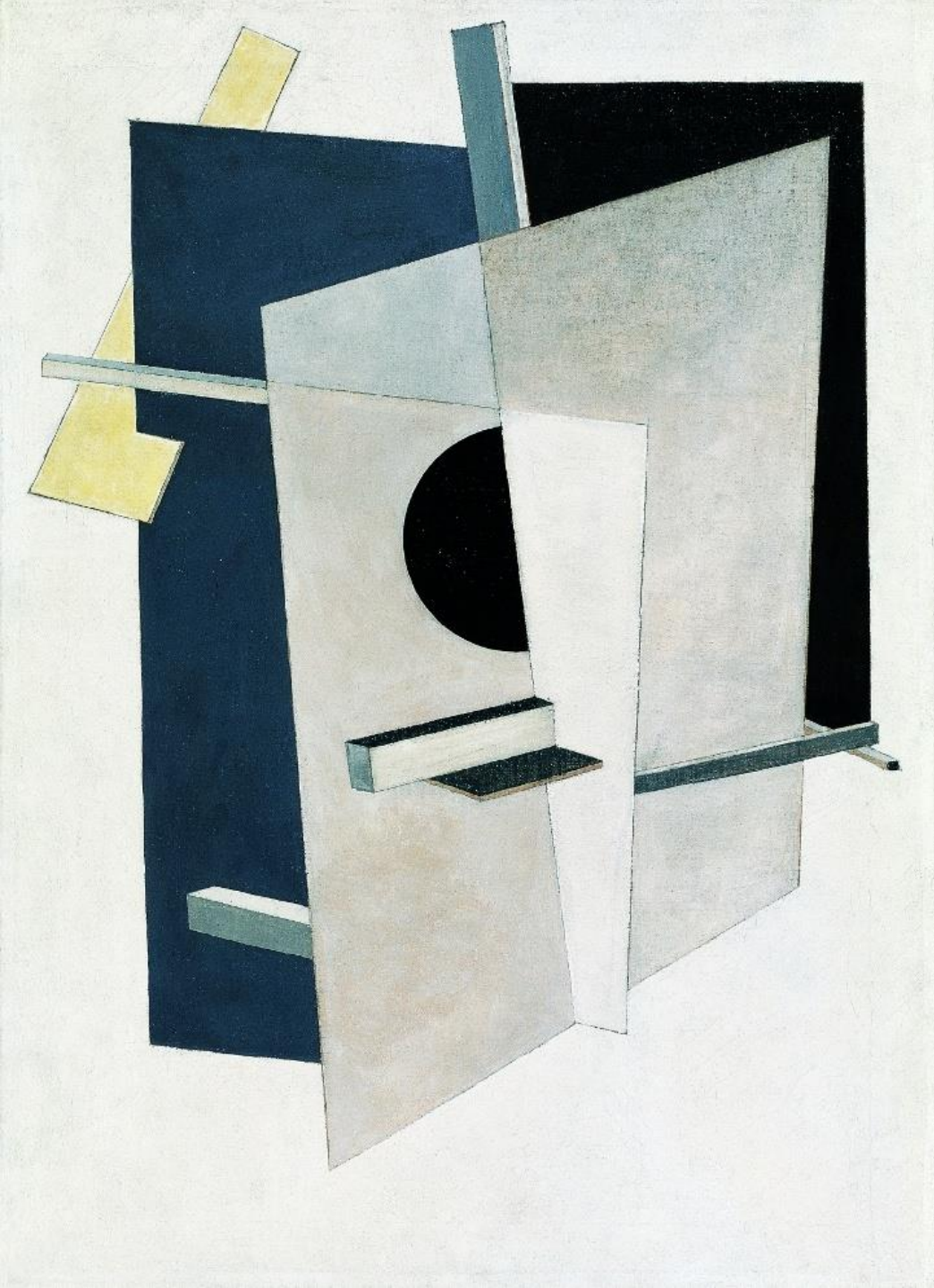

DARSTELLUNG

El Lissitzky – Proun 6

DRAUFSICHT

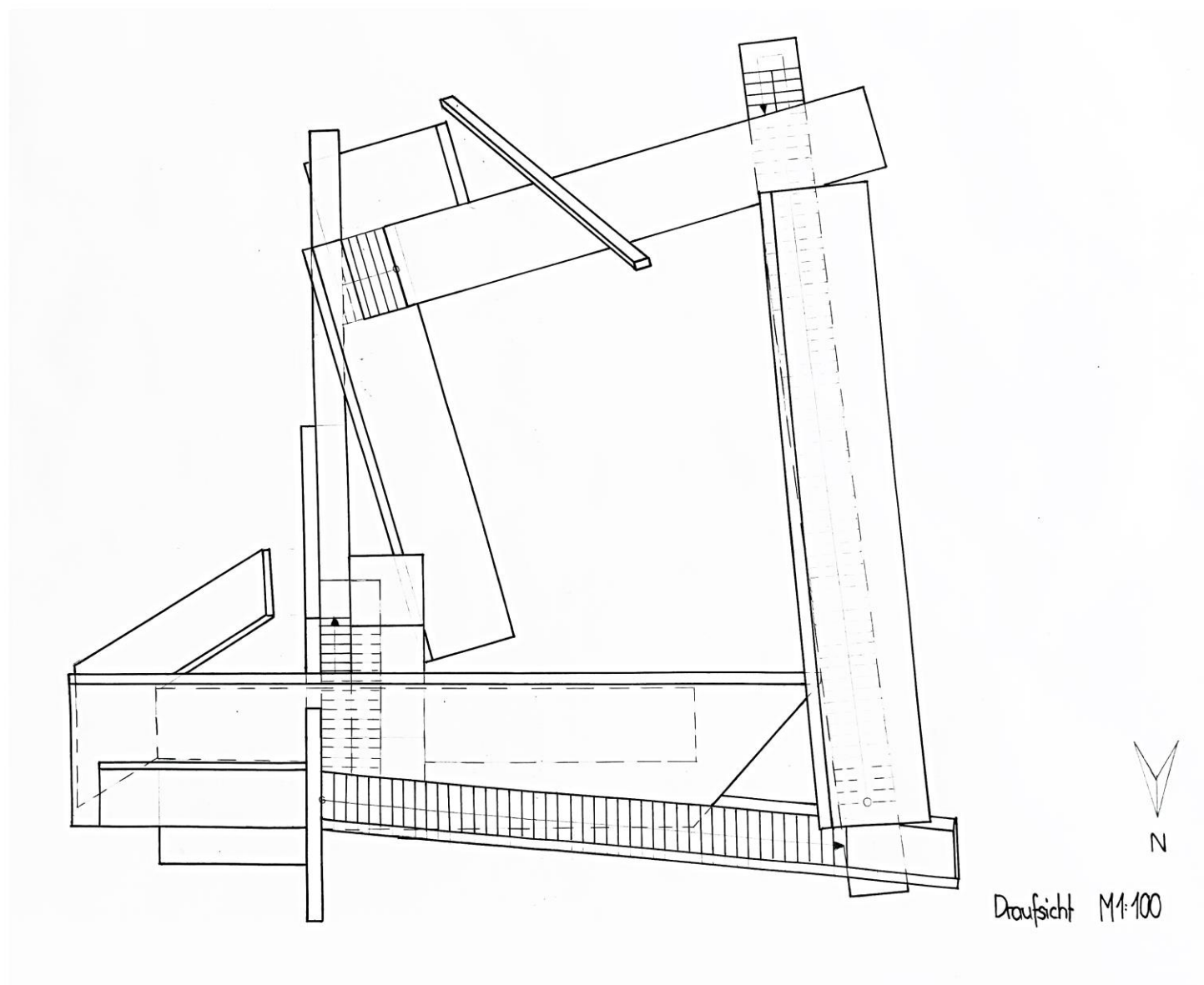

GRUNDRISS

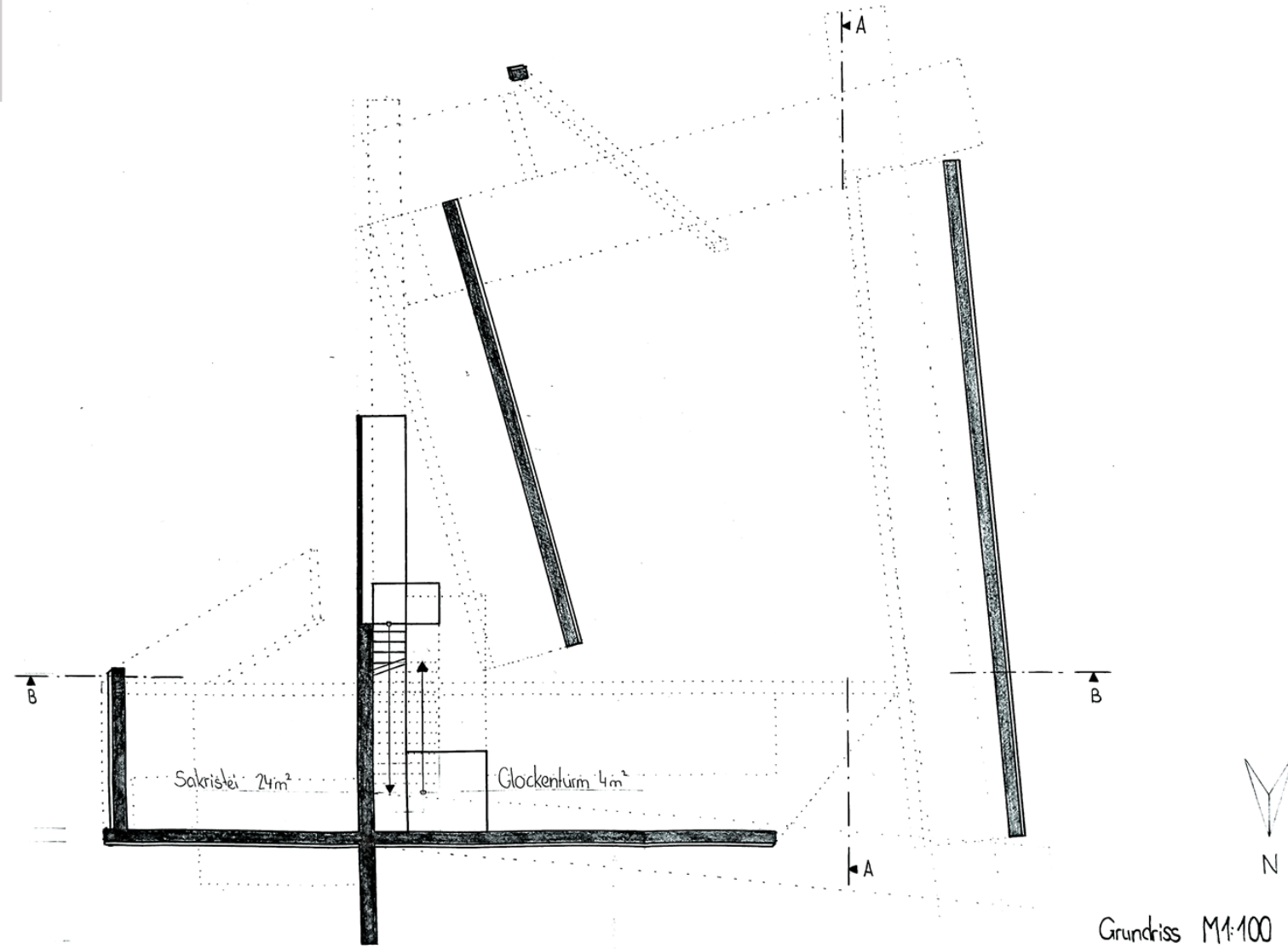

Ostansicht

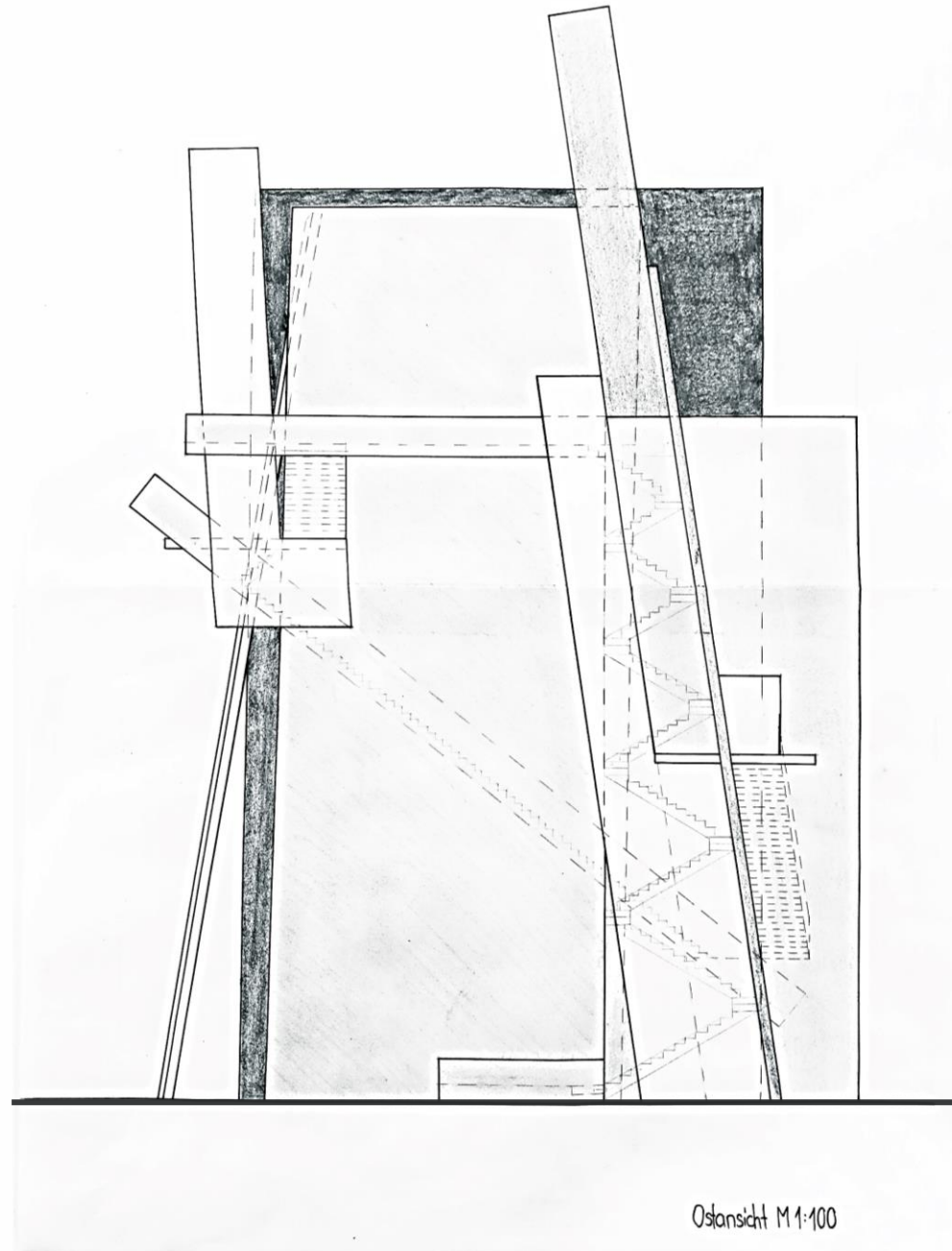
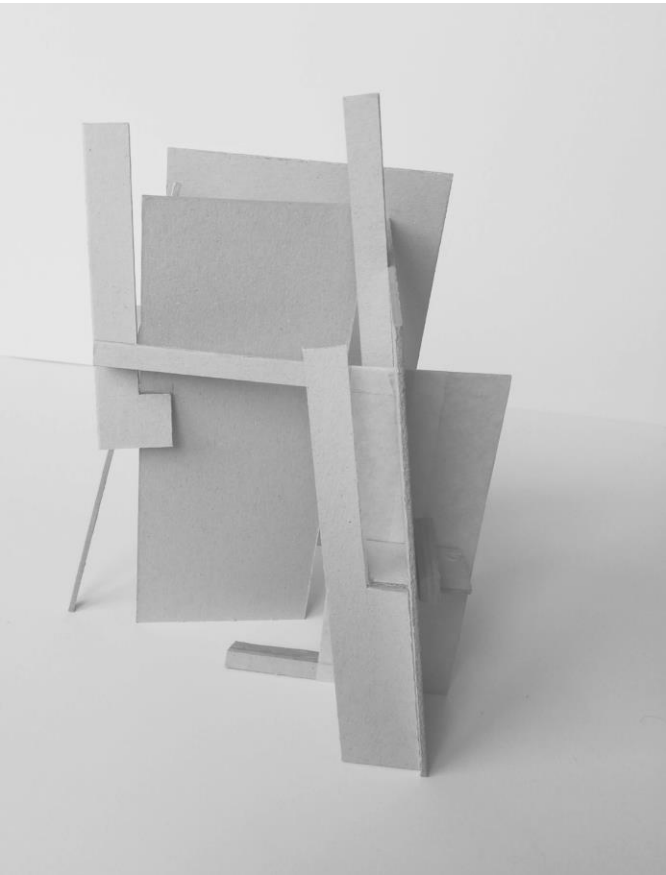

SÜDANSICHT

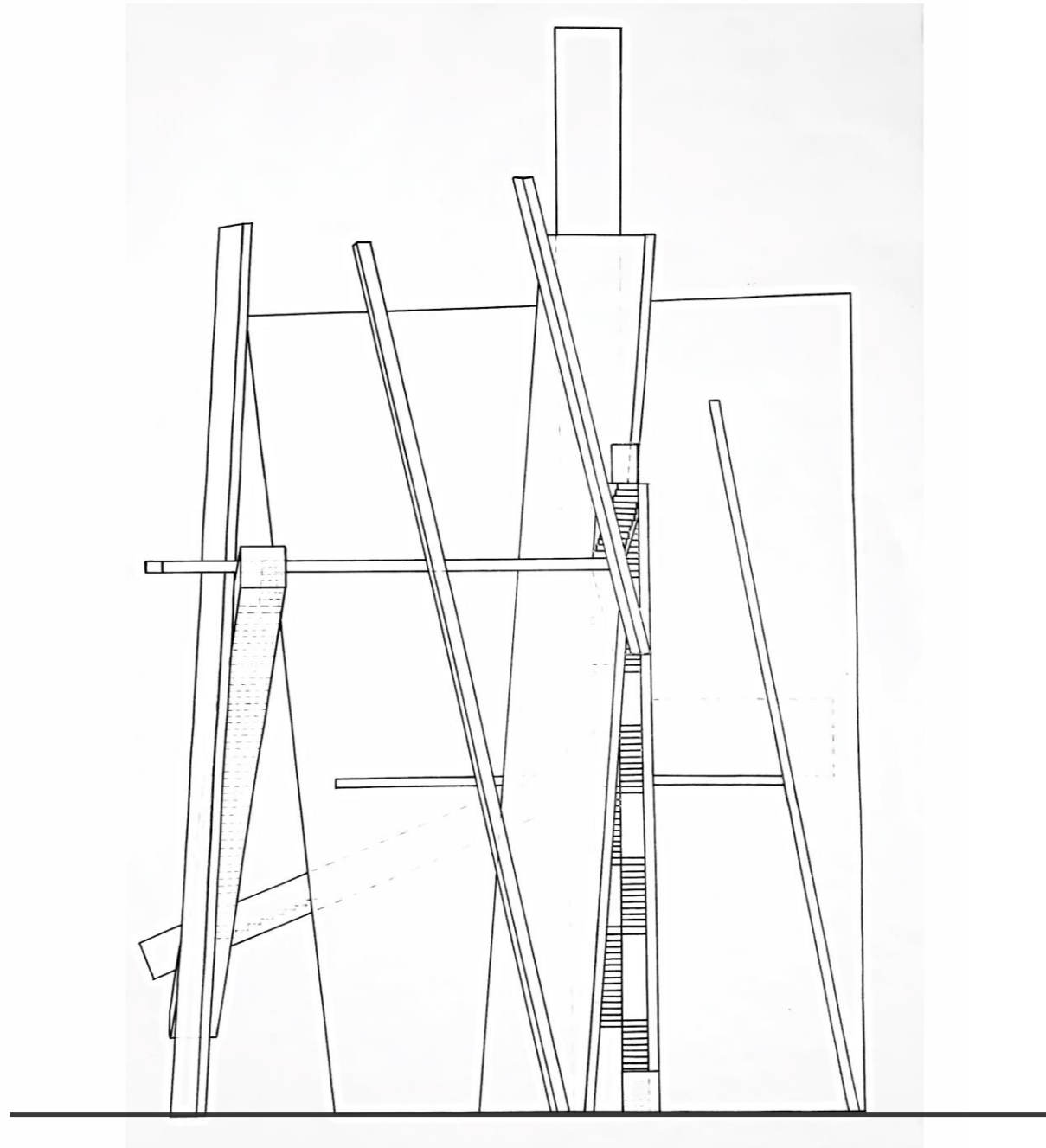
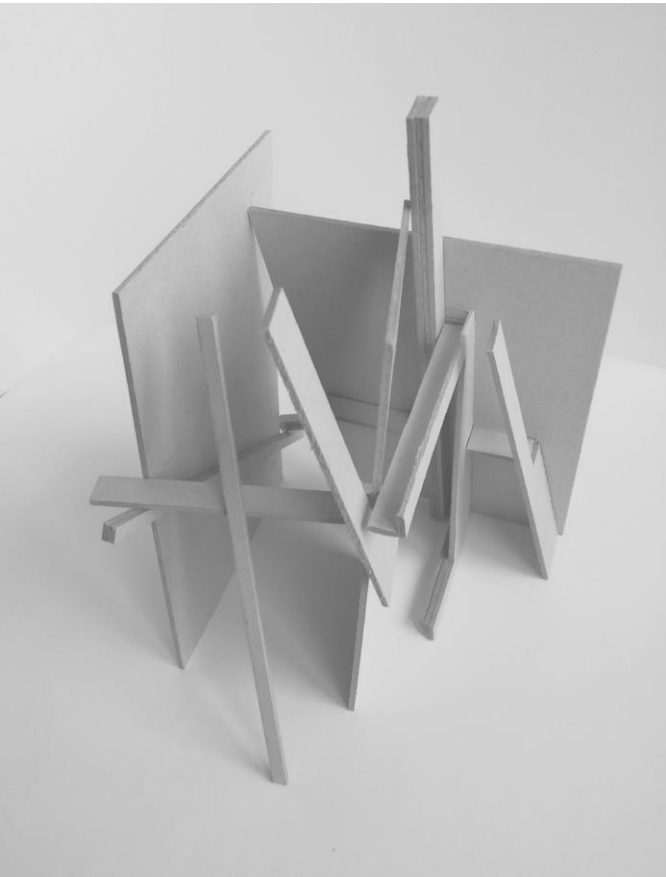

NORDANSICHT

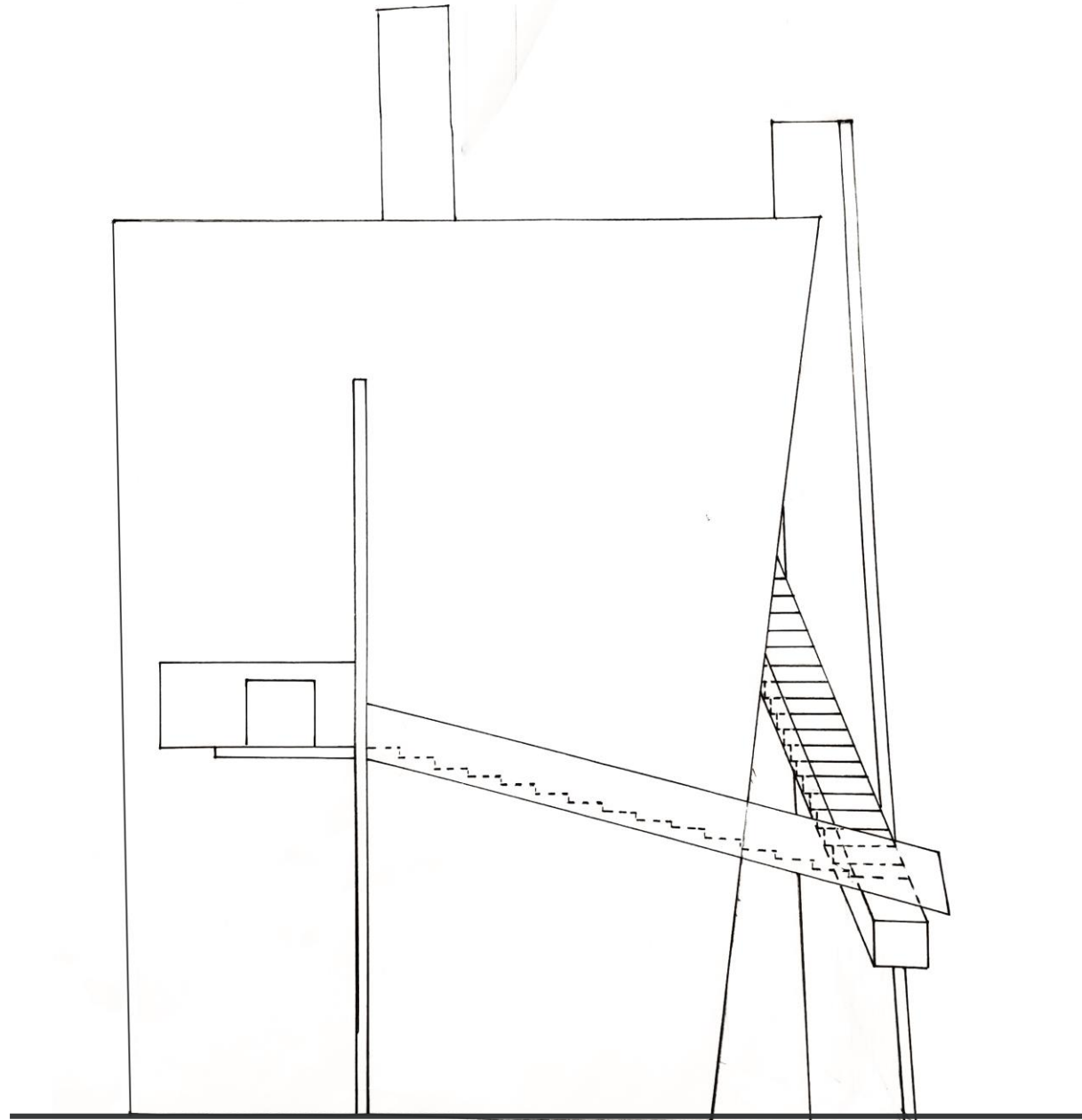
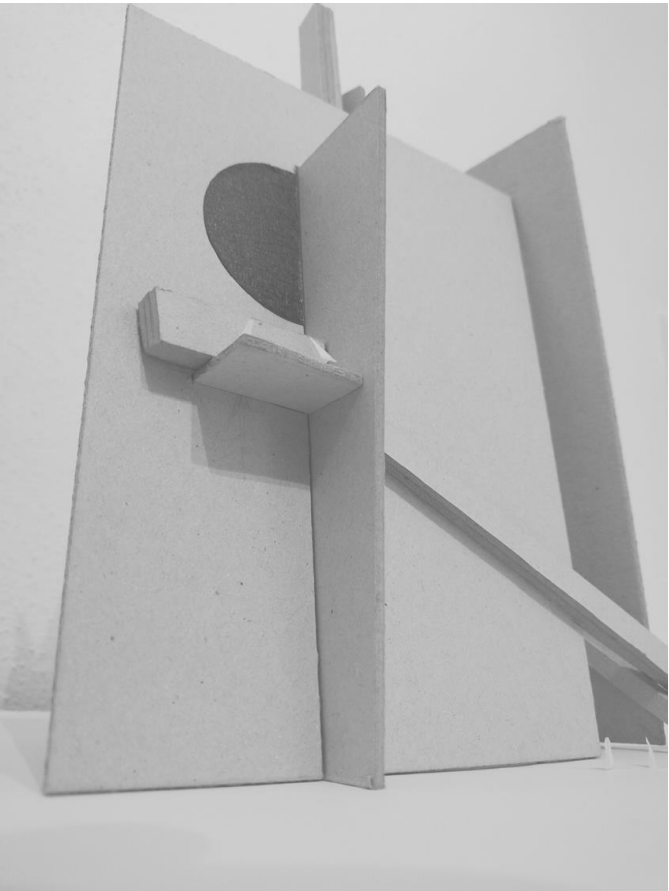

A-A SCHNITT

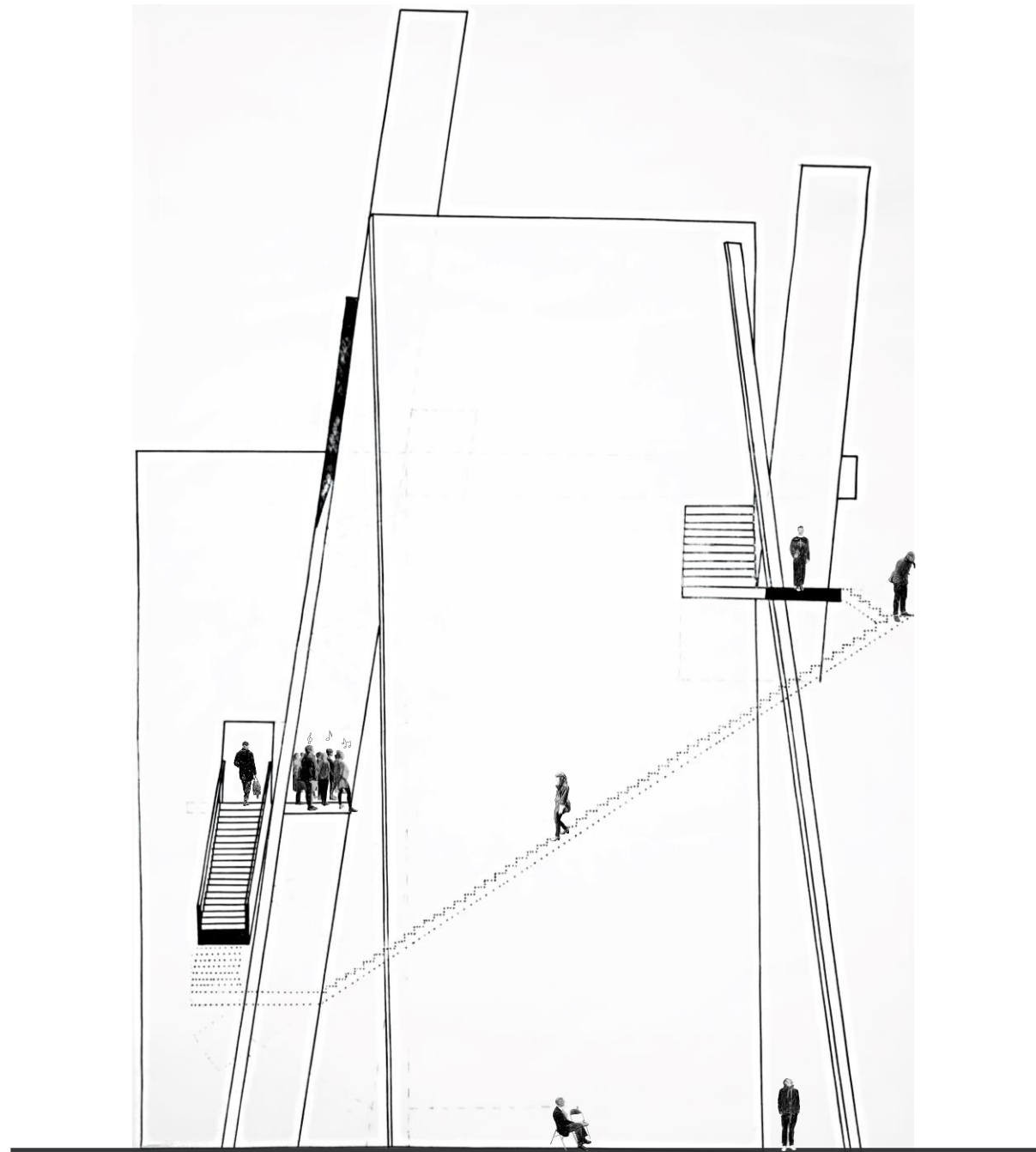

B-B SCHNITT

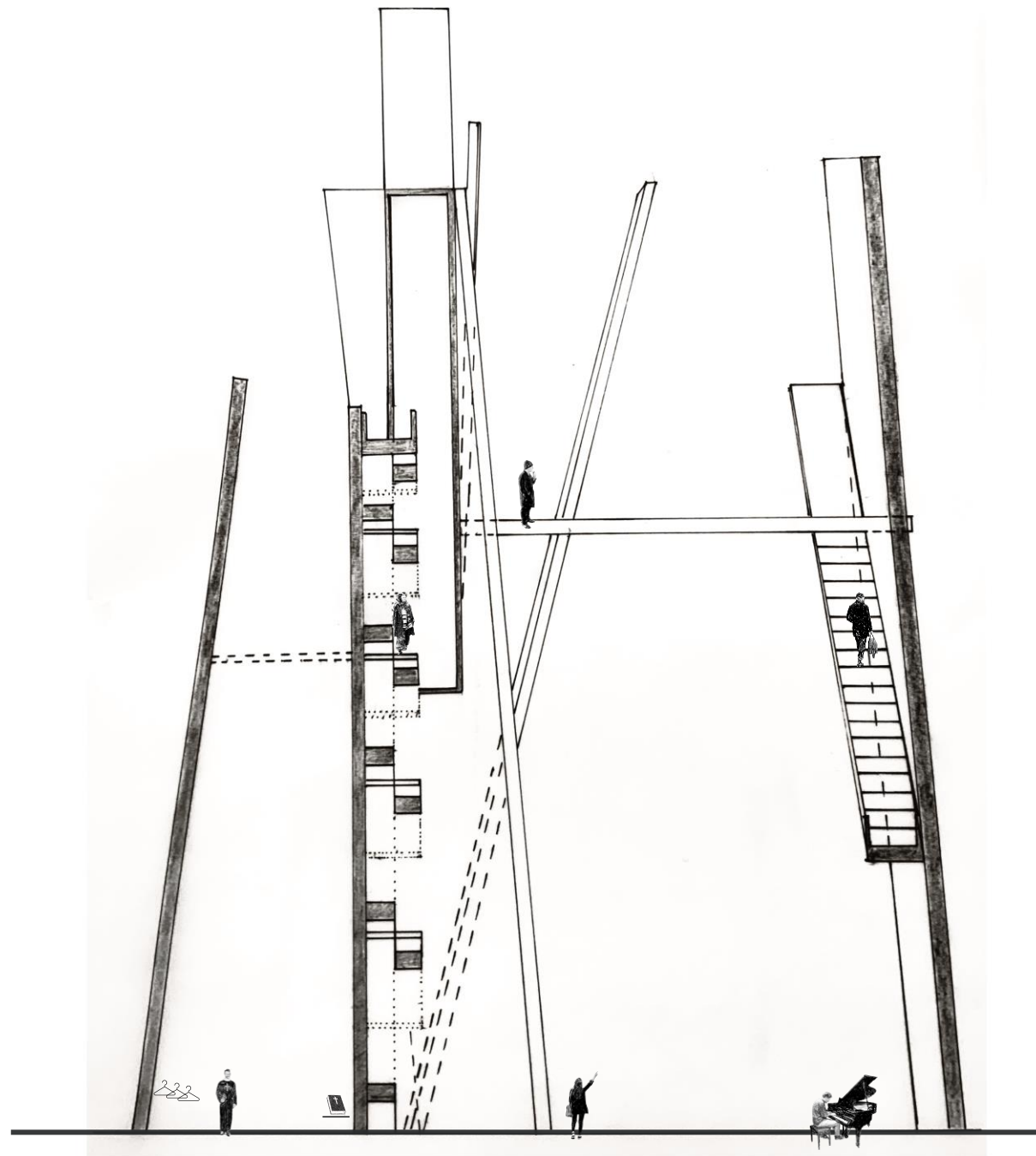

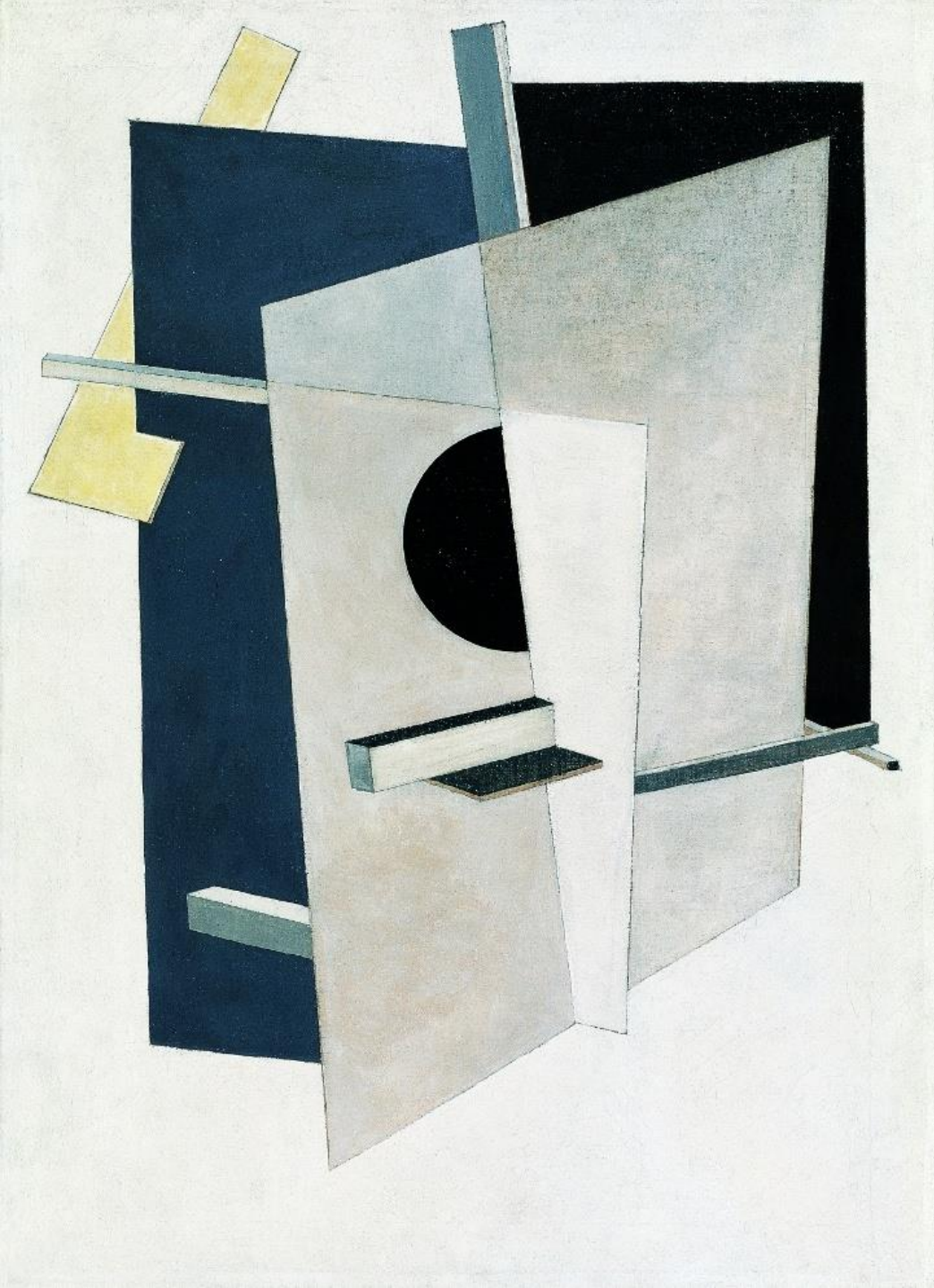

FUNKTION

El Lissitzky – Proun 6

WEGE

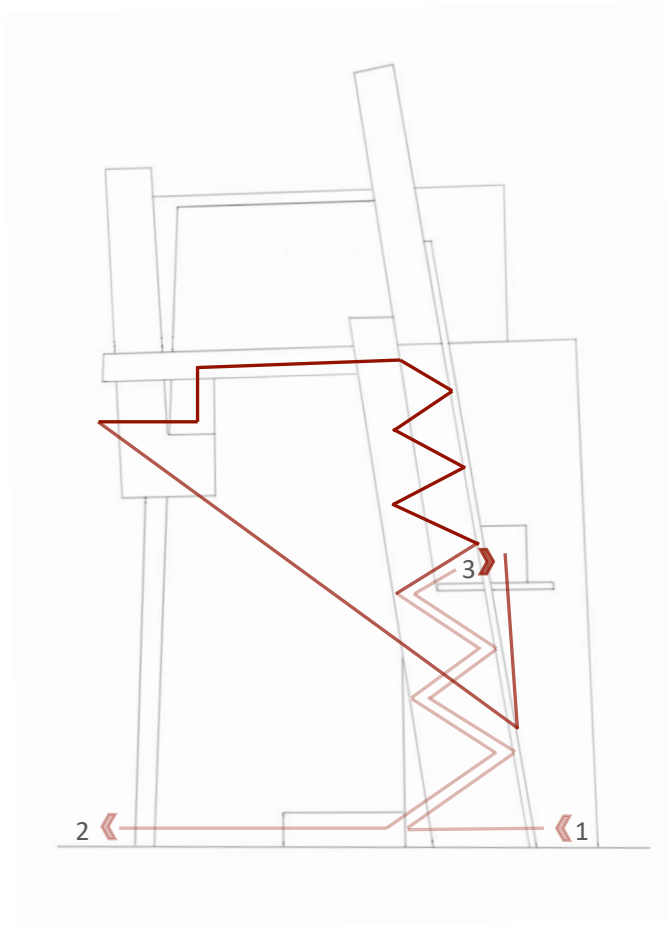

- 1: Eingang
- 2: Ausgang
- 3: Durchgang von
Innen nach Außen

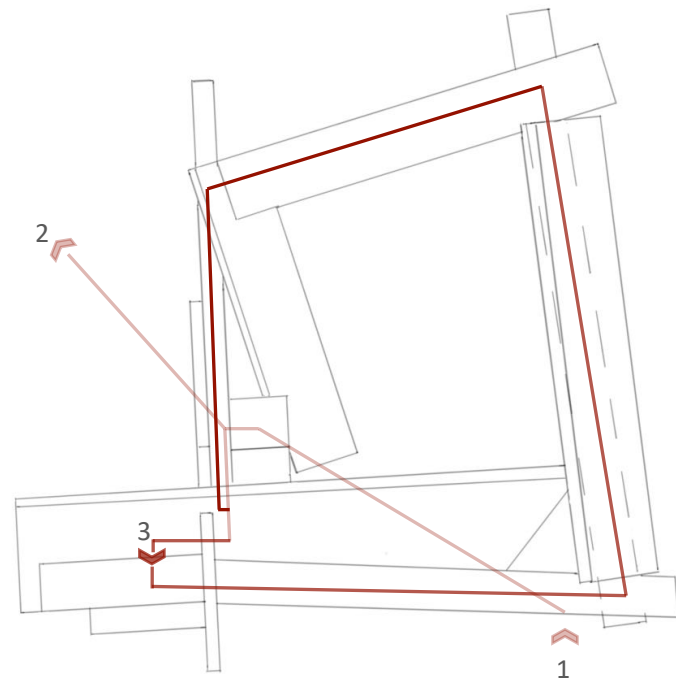

FUNKTION

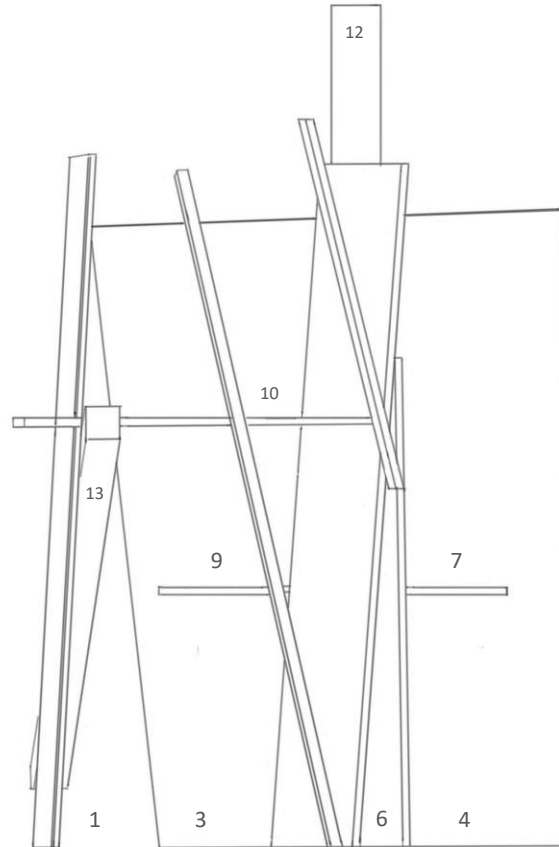
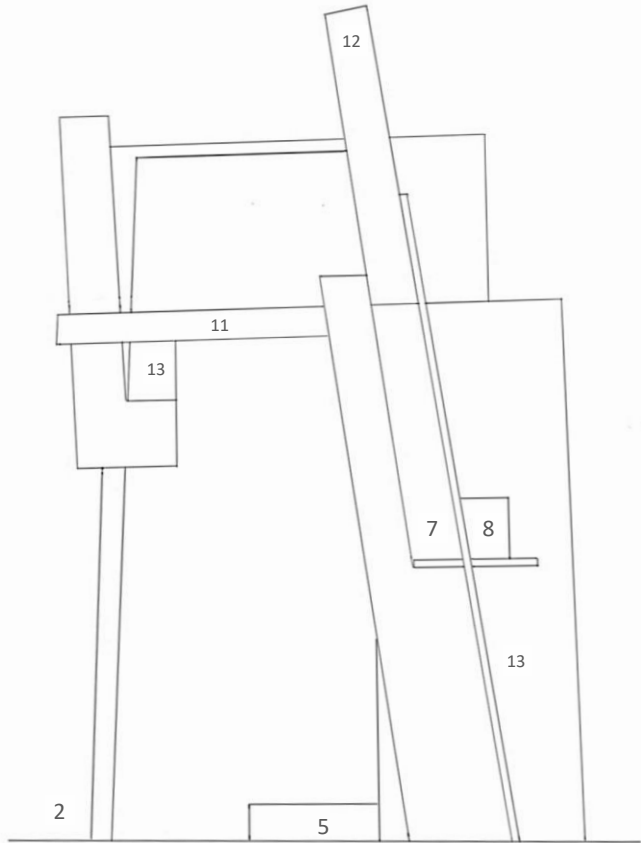

- 1: Haupteingang
- 2: Ausgang
- 3: Kirchsaal
- 4: Sakristei
- 5: Toiletten
- 6: Treppenhaus
- 7: Galerie mit Durchgang nach Außen
- 8: Glastunnel mit Ausblick
- 9: Chorgalerie
- 10: Altar
- 11: Übergang zum Treppenhaus
- 12: Glockenturm
- 13: Treppen

KONSTRUKTION

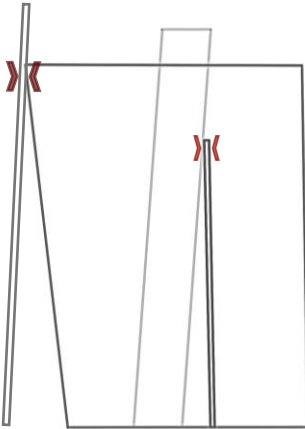
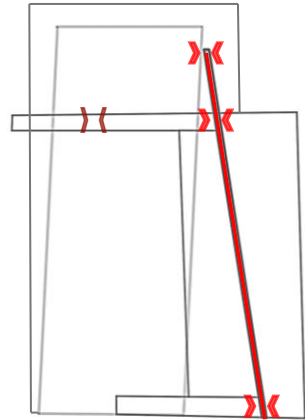

Balken & Flächen

-gesteckt

-gelehnt

-halten sich gegenseitig

-Gründung durch Betonsockel
im Fundament

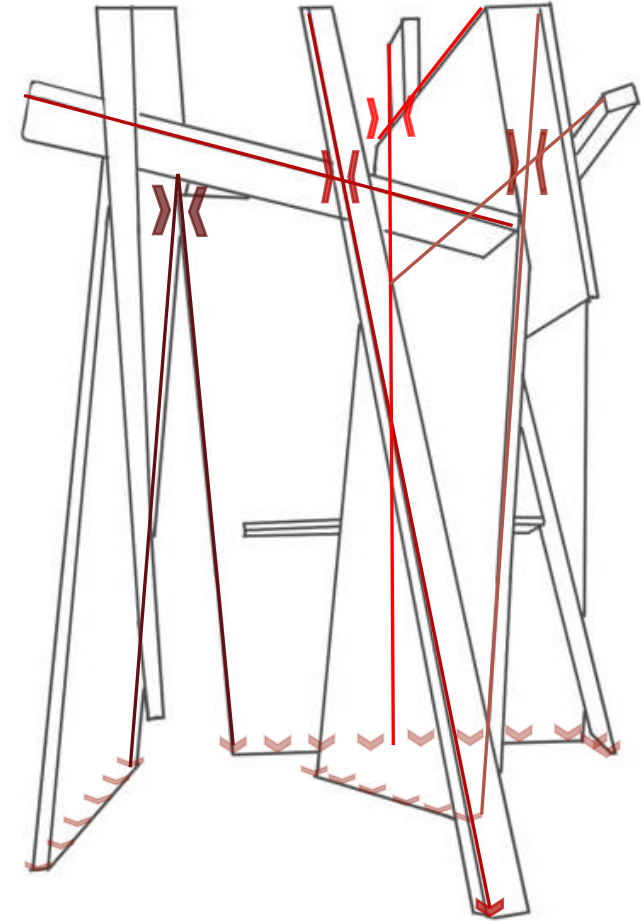

RAUM

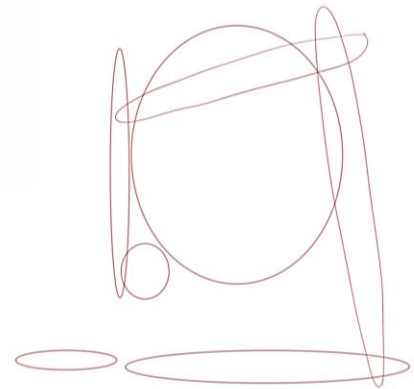
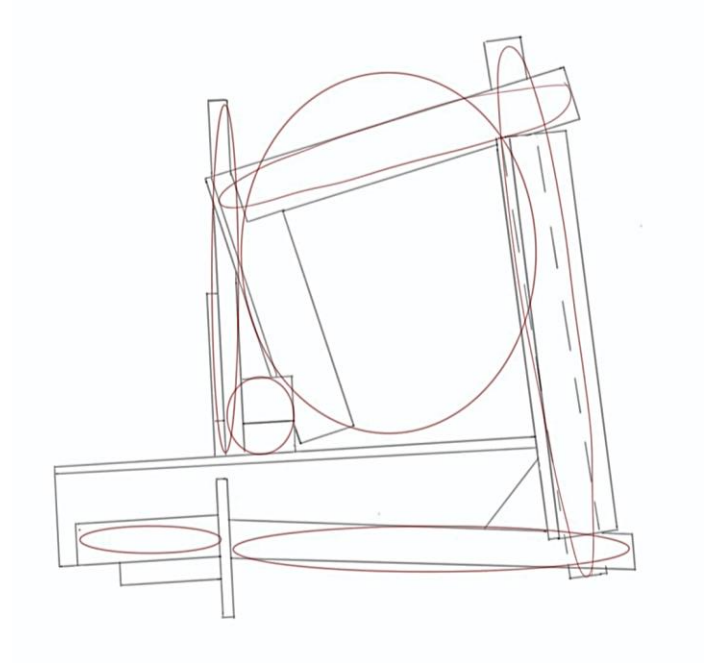
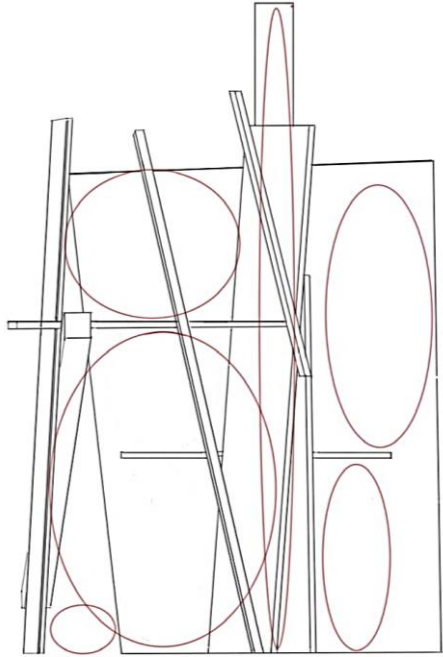
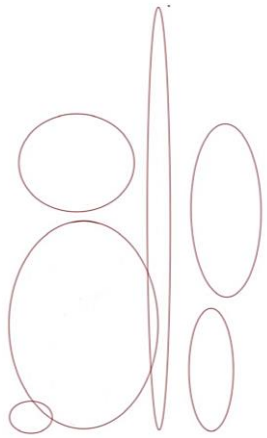

LICHTEINFLUSS



Tag

monolithischer
Baukörper wirkt für sich

Nacht

Kirchenerlebnis neu
interpretiert

Baukörper erstrahlt
isoliert von Umgebung



LICHTEINFLUSS

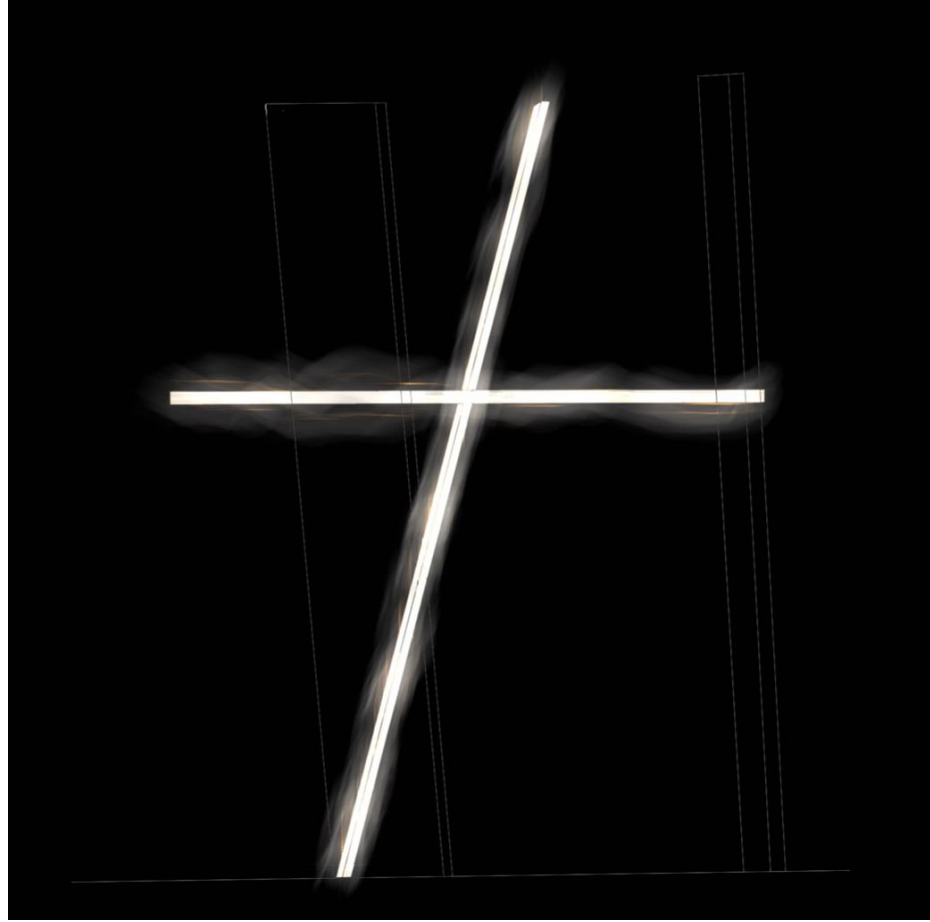
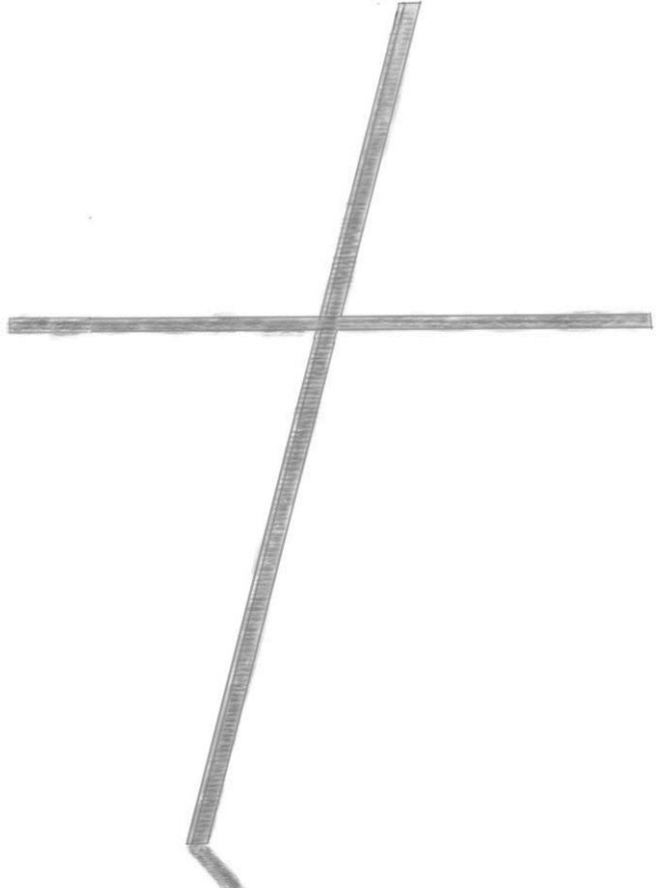

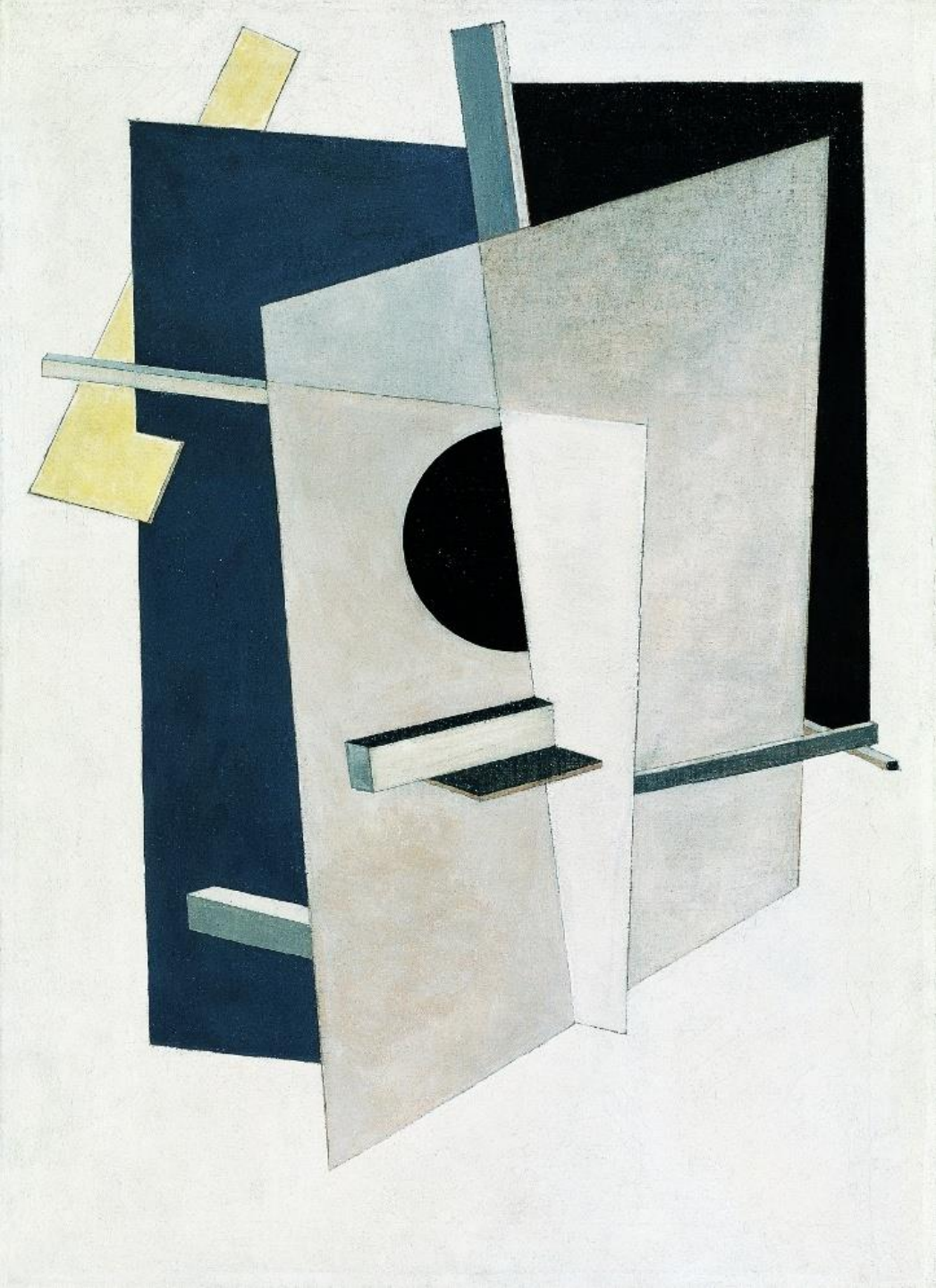

KONTEXT

El Lissitzky – Proun 6



Pilgerstätte

In südlicher Region

Umgebung verläuft sich in unendliche Weiten

Blick von Außen



